



# BradyPrinter i7100

INDUSTRIAL LABEL PRINTER

PRINTER SETTINGS,  
CONFIGURATIONS AND  
CONNECTIVITY MANUAL

## Table of Contents

<b>1</b>	<b>Introduction</b> .....	<b>5</b>
<b>2</b>	<b>Connecting Label Printer to Computer</b> .....	<b>6</b>
2.1	Print Services Raw-IP and LPR/LPD in MS Windows .....	6
2.2	Adjusting Windows Printer Setting .....	6
2.3	Connecting Label Printer via Ethernet Interface .....	7
2.4	Setting Up a WLAN Connection .....	7
2.5	Connecting Label Printer via USB Interface .....	7
2.6	Connecting Label Printer via RS-232 interface .....	8
2.7	Setting Up a Bluetooth Connection .....	8
<b>3</b>	<b>Menu</b> .....	<b>9</b>
3.1	Structure of the Menu .....	9
3.2	Navigating in the Menu .....	10
3.3	Service Key .....	11
<b>4</b>	<b>Info</b> .....	<b>12</b>
<b>5</b>	<b>Security</b> .....	<b>13</b>
<b>6</b>	<b>Configuration</b> .....	<b>14</b>
6.1	Configuration via Control Panel .....	14
6.1.1	Printing .....	14
6.1.2	Labels .....	15
6.1.3	Ribbon .....	15
6.1.4	Tearing-off .....	16
6.1.5	Cutting .....	16
6.1.6	Peeling-off .....	16
6.1.7	Labelling .....	17
6.1.8	Interfaces .....	18
6.1.9	Errors .....	20
6.1.10	Region .....	21
6.1.11	Time .....	21
6.1.12	Display .....	22
6.1.13	Interpreter .....	22
6.1.14	ZPL .....	22
6.2	Configuration via the Web Interface .....	23
6.2.1	Status Tab .....	24
6.2.2	Setup Tab .....	25
6.2.3	Security Tab .....	26
6.2.4	Devices Tab .....	27
6.2.5	Fonts Tab .....	27
6.2.6	Help Menu .....	28
<b>7</b>	<b>Test Functions</b> .....	<b>29</b>
7.1	Overview .....	29
7.2	Status Print .....	29
7.3	Font list .....	30
7.4	Device List .....	31
7.5	Test Grid .....	32
7.6	WiFi Status .....	33
<b>8</b>	<b>Diagnostic Functions</b> .....	<b>34</b>
8.1	Printhead .....	34
8.2	ASCII Dump Mode .....	35
8.3	Label Profile .....	36
8.4	Event Log .....	37
8.5	Save Data Steam .....	38
8.6	Save Print Image .....	38
8.7	Save System Log .....	39

## Table of Contents

<b>9</b>	<b>Extras</b> .....	<b>40</b>
9.1	Firmware Update.....	40
9.2	Save Settings.....	40
9.3	Load Settings .....	41
9.4	Reset Settings.....	41
9.5	Reset Passwords .....	41
9.6	Cleaning Interval .....	42
9.7	Legal Notices .....	42
<b>10</b>	<b>Help</b> .....	<b>43</b>
<b>11</b>	<b>Service Functions</b> .....	<b>44</b>
11.1	Reset Service Counter.....	44
11.2	Calibrate Label Sensor.....	44
11.3	Printhead Zero Position X .....	45
11.4	Printhead Zero Position Y .....	45
11.5	Printer Model.....	45
<b>12</b>	<b>I/O Interface</b> .....	<b>46</b>
12.1	Pin Assignment .....	46
12.2	Circuit Diagram of Inputs and Outputs.....	47
12.3	Solution Examples .....	48
12.3.1	Peeling-off on Demand with Present Sensor.....	48
12.3.2	Peeling-off on Demand without Present Sensor.....	49
12.3.3	Cutting on Demand with Cutter .....	52
12.3.4	Pausing and Continuing a Print Job .....	53
<b>13</b>	<b>FTP Printer Management</b> .....	<b>54</b>
13.1	FTP Login.....	54
13.2	FTP Printing .....	54
13.3	FTP Access to Storage Devices.....	54
13.4	FTP Firmware Update.....	55
<b>14</b>	<b>Storage Devices</b> .....	<b>56</b>
14.1	Suitable Storage Devices.....	56
14.2	Installation .....	56
14.3	Directory Structure .....	56
14.4	Writing .....	57
14.5	Storage Device Functions .....	57
14.5.1	Load Label.....	57
14.5.2	Print File List.....	58
14.5.3	Copy Files.....	58
14.5.4	Format Storage.....	58
14.5.5	Default Storage.....	59
<b>15</b>	<b>Remote Access via VNC</b> .....	<b>59</b>
<b>16</b>	<b>External Keyboard</b> .....	<b>60</b>
16.1	Connecting External Keyboard .....	60
16.2	Keyboard Assignment .....	60
16.3	Special Key Functions.....	61
<b>17</b>	<b>Updating Firmware on the i7100 Industrial Label Printer</b> .....	<b>62</b>
<b>18</b>	<b>Index</b> .....	<b>63</b>

## Configuration Manual for the following products:

Model	Configuration
i7100	i7100 Standard (300 & 600 dpi)
	i7100 Peel (300 & 600 dpi)

# BradyPrinter i7100

INDUSTRIAL LABEL PRINTER

### Disclaimer

This manual is proprietary to Brady Worldwide, Inc. (hereafter "Brady"), and may be revised from time to time without notice. Brady disclaims any understanding to provide you with such revisions, if any. This manual is copyrighted with all rights reserved. No portion of this manual may be copied or reproduced by any means without the prior written consent of Brady.

While every precaution has been taken in the preparation of this document, Brady assumes no liability to any party for any loss or damage caused by errors or omissions or by statements resulting from negligence, accident, or any other cause. Brady further assumes no liability arising out of the application or use of any product or system described, herein; nor any liability for incidental or consequential damages arising from the use of this document. Brady disclaims all warranties of merchantability of fitness for a particular purpose.

Brady reserves the right to make changes without further notice to any product or system described herein to improve reliability, function, or design.

### Trademark

Windows, Microsoft and Internet Explorer are registered trademarks of the Microsoft Corporation.

Bluetooth is a registered trademark of Bluetooth SIG, Inc.

Firefox is a registered trademark of Mozilla Foundation.

ZPL and Zebra logo are registered trademarks of ZIH Corporation.

BradyPrinter™ is a trademark of Brady Worldwide, Inc. All brand or product names referenced in this manual are trademarks (™) or registered trademarks (®) of their respective companies or organizations. ©2016 Brady Corporation. All rights reserved.

### Editor

Regarding questions or comments please contact Brady Technical Support.

### Topicality

Due to the constant further development of products discrepancies between documentation and product can occur. Please check BradyID.com for the latest update.

### Terms and conditions

Deliveries and performances are effected under the General conditions of sale of BradyPrinter i7100.

### Brady Warranty

Our products are sold with the understanding that the buyer will test them in actual use and determine for him or herself their adaptability to his/her intended uses. Brady warrants to the buyer that its products are free from defects in material and workmanship, but limits its obligation under this warranty to replacement of the product shown to Brady's satisfaction to have been defective at the time Brady sold it. This warranty does not extend to any persons obtaining the product from the buyer.

THIS WARRANTY IS IN LIEU OF ANY OTHER WARRANTY, EXPRESS OR IMPLIED, INCLUDING, BUT NOT LIMITED TO, ANY IMPLIED WARRANTY OF MERCHANTABILITY OR FITNESS FOR A PARTICULAR PURPOSE, AND OF ANY OTHER OBLIGATIONS OR LIABILITY ON BRADY'S PART. UNDER NO CIRCUMSTANCES WILL BRADY BE LIABLE FOR ANY LOSS, DAMAGE, EXPENSE OR CONSEQUENTIAL DAMAGES OF ANY KIND ARISING IN CONNECTION WITH THE USE, OR INABILITY TO USE, BRADY'S PRODUCTS.

## 1 Introduction

Important information and instructions in this documentation are designated as follows:



### **Danger!**

Draws attention to an exceptionally great, imminent danger to your health or life due to hazardous voltages.



### **Danger!**

Draws attention to a danger with high risk which, if not avoided, may result in death or serious injury.



### **Warning!**

Draws attention to a danger with medium risk which, if not avoided, may result in death or serious injury.



### **Caution!**

Draws attention to a danger with low risk which, if not avoided, may result in minor or moderate injury.



### **Attention!**

Draws attention to potential risks of property damage or loss of quality.



### **Note!**

Advices to make work routine easier or on important steps to be carried out.



### **Environment!**

Gives you tips on protecting the environment.



Handling instruction



Reference to section, position, illustration number or document.



Option (accessories, peripheral equipment, special fittings).

*Time*

Information in the display.

## 2 Connecting Label Printer to Computer

Choose from the following options for connecting a computer to the label printer:

- Direct connection to the Ethernet interface (6) ▷ "2.3" on page 7.
- Connection via a computer network to the Ethernet interface (6) ▷ "2.3" on page 7.
- WLAN connection.
- Connection to the full-speed USB slave interface (5) ▷ "2.5" on page 7.
- Connection to the RS-232 interface.
- Connection via optional Bluetooth adapter connected to an USB master interface (4/9).

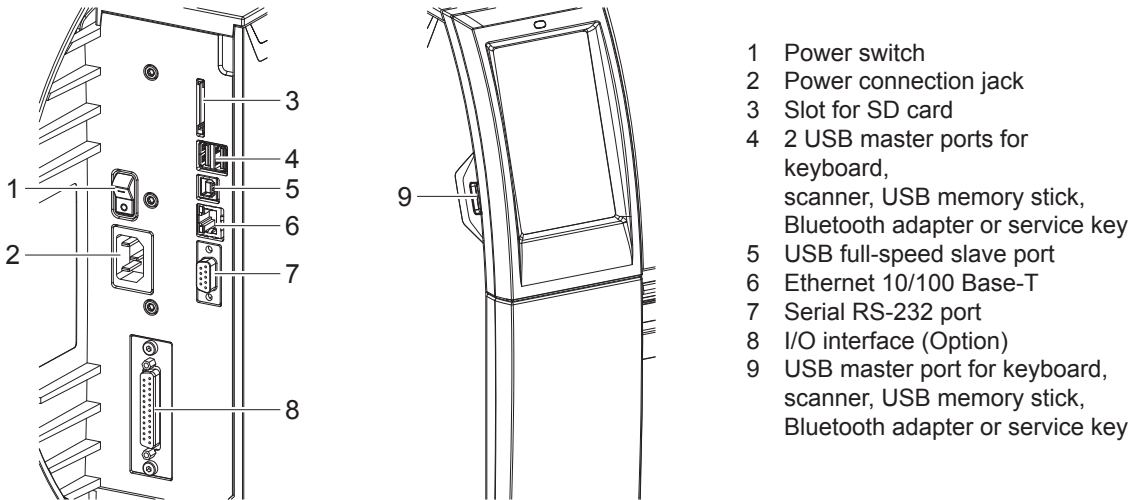

Figure 1 Connections

### 2.1 Print Services Raw-IP and LPR/LPD in MS Windows

- ▶ Install a standard TCP/IP port as additional port for printing.
- ▶ During installation of the new port choose between "Raw" and "LPR"
- ▶ Raw-IP: Enter the same port address in the printer which you have selected during installation.



**Notice!**

In the delivery status the print services RawIP (Port 9100) and LPD are activated on the printer ▷ page 19.

### 2.2 Adjusting Windows Printer Setting

When the printer driver valid for your Windows version is installed on your computer, Windows standard applications can be used to edit the label contents and to start the print jobs. To use the Raw-IP or LPR/LPD print services, the Windows printer settings must be adjusted:

1. Open the folder containing the printers via Start > Settings > Printers.
2. Right-click the icon of the label printer.  
A pop-up menu appears.
3. Select "Properties" in the pop-up menu.
4. Open the "Details" or "Connections" tab.  
This tab contains, among other things, the connections which were also set up when the print services were installed. The names of these connections depend on the installation tool used.
5. Select the Raw-IP or LPR connection.
6. Click **OK**.

## 2 Connecting Label Printer to Computer

### 2.3 Connecting Label Printer via Ethernet Interface

To connect the label printer to a network jack, a patch cable with an RJ45 plug for 10 Base T or 100 Base T is required.



#### Attention!

- ▶ Use a shielded cable to connect the printer to the network.



- ▶ Connect computer and label printer with a suitable cable.
- ▶ Make the settings for operation of the Ethernet interface ▷ 6.1.8 on page 18.
- ▶ Set up print service if necessary ▷ 2.1 on page 6.
- ▶ Adjust Windows printer setting ▷ 2.2 on page 6.



#### Attention!

- ▶ Do not change the settings of the "IP" and "Gateway" on the printer web interface, as otherwise the connection to the printer may be lost.

### 2.4 Setting Up a WLAN Connection

- ▶ Start menu.
- ▶ Select *Setup > Interfaces > WLAN*.
- ▶ Activate *WLAN* ▷ 6.1.8 on page 18.
- ▶ Select *Access-Point*.  
The search for access-points will be started.  
The display shows the available access-points including the hidden access-points.
- ▶ Select an access point and confirm with .
- ▶ For hidden access-points enter the *SSID*.
- ▶ Setup *DHCP* or *IP* and *Mask* and if necessary *Gateway* ▷ 6.1.8 on page 18.
- ▶ If the network is protected a prompt to enter the passkey appears in the printer display. Enter the passkey and select .
- ▶ Set up print service if necessary ▷ 2.1 on page 6.
- ▶ Adjust Windows printer setting ▷ 2.2 on page 6.



#### Attention!

- ▶ Do not change the settings of the "IP" and "Gateway" on the printer web interface, as otherwise the connection to the printer may be lost.

### 2.5 Connecting Label Printer via USB Interface

The full-speed USB interface allows the label printer to be operated via a USB interface of a computer running one of the 32bit or 64bit operating systems:

- Windows Vista
- Windows 7
- Windows 8
- Windows 8.1
- Windows 10
- Windows Server 2003
- Windows Server 2008
- Windows Server 2008 R2
- Windows Server 2012
- Windows Server 2012 R2
- Windows Server 2016

A printer driver must be installed if a USB interface will be used for connection. The printer driver for your unit is found on the "Printer Driver CD" which is included in the scope of delivery or on the internet.

1. Switch label printer off.
2. Connect computer and label printer with an A-B cable.
3. Switch computer on.
4. Place the "Printer Driver CD" in the DVD drive.
5. Exit all programs currently running.
6. Switch printer on.  
The Windows Installation Wizard is started automatically.
7. Follow the on-screen instructions. After successful installation, an icon for the label printer appears in the Windows "Printer" system folder.
8. Click icon in "Printer" system folder and make printer settings if necessary.

## 2 Connecting Label Printer to Computer

### 2.6 Connecting Label Printer via RS-232 interface

Pin	Designation	Function
1	CD	Carrier Detect
2	TxD	Transmit Data
3	RxD	Receive Data
4	DTR	Data Terminal Ready (not used)
5	GND	Ground
6	DSR	Data Set Ready (not used)
7	RTS	Request to Send
8	CTS	Clear to Send
9	RI	Ring Indication (not used)

Table 1 Pin assignment of the RS-232 interface

- ▶ Connect the 9-pin socket to the matching port of the computer.
- ▶ Install the Windows Printer Driver from the DVD included in the delivery contents of the printer.
- ▶ Configure the interface parameters of the interface matching to the settings of the computer. ▶ page 19.

### 2.7 Setting Up a Bluetooth Connection

To set up a Bluetooth connection a Bluetooth USB Adapter (Part No. 149080) is required.



**Notice!**

**A Bluetooth software is delivered with the Bluetooth USB Adapter.**

1. Connect the Bluetooth USB adapter an to an USB master interface.
2. Switch on the printer.
3. Install the Bluetooth software on the computer.
4. Start the Bluetooth software.
5. Start "Search devices".  
The printer will be shown in a list of Bluetooth devices.
6. Optional : For an well-defined connection of the devices select the printer and click "Connect Devices".  
Either a passkey will be shown or a window will be opened where a passkey can be set. ▶ Set a passkey if necessary .  
The display of the printer shows a prompt to enter the passkey too. ▶ Enter the passkey.
7. Select in the software "Connecting" via "Serial Bluetooth Interface".  
The new interface, e.g COM5, will be shown
8. Install the current printer with connection via the new COM interface in the label software or in Windows.



### 3 Menu

#### 3.1 Structure of the Menu

The menu contains setting options on several levels for configuring the label printer. In addition, the menu features test and diagnostic functions for supporting the configuration or checking the function of the label printer.

1st Selection Level	2nd Selection Level	3rd Selection Level	
 Info			
 Storage			
	 Printing		
	 Labels		
	 Ribbon		
	 Tearing-off		
	 Cutting		
	 Peeling-off		
	 Labelling		
		 Ethernet	
		 WLAN	
		 Network services	
		 RS-232	
	 Errors		
	 Region		
	 Time		
	 Display		
 Interpreter			
 ZPL			
 Test			
 Security			
 Diagnostics			
 Extras			
 Help			
 Service			

Table 2 Structure of the menu

### 3 Menu

#### 3.2 Navigating in the Menu

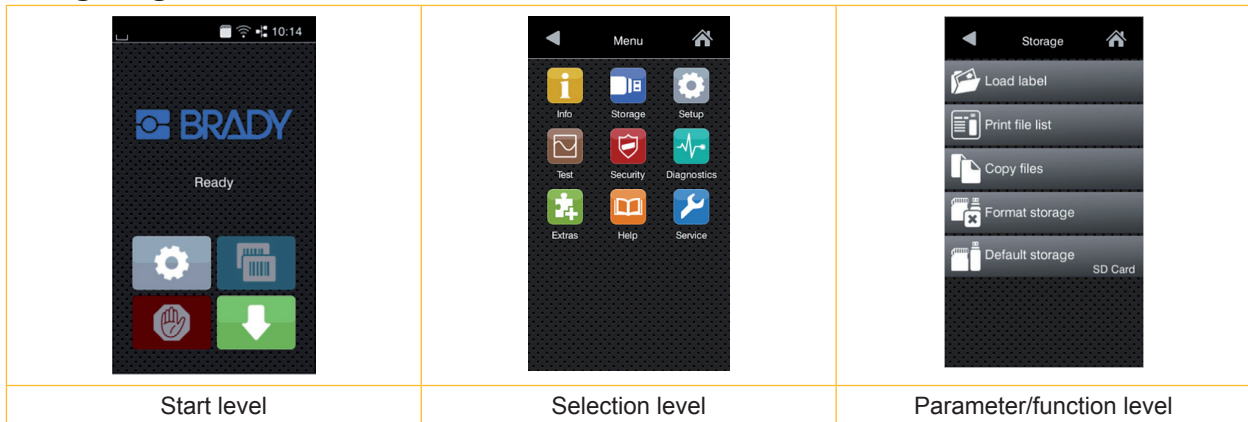





Figure 2 Menu levels

- ▶ To open the menu select  on the start screen.
- ▶ Select a theme in the selection level.  
Several themes have substructures again with selection levels.  
To return from the current level to the upper one select . To leave the menu select .
- ▶ Continue the selection until the parameter/function level is reached.
- ▶ Start a function. The printer will carry out the function possibly after a preparing dialogue.  
- or - Select a parameter to set. The setup possibilities are depending from the parameter type.

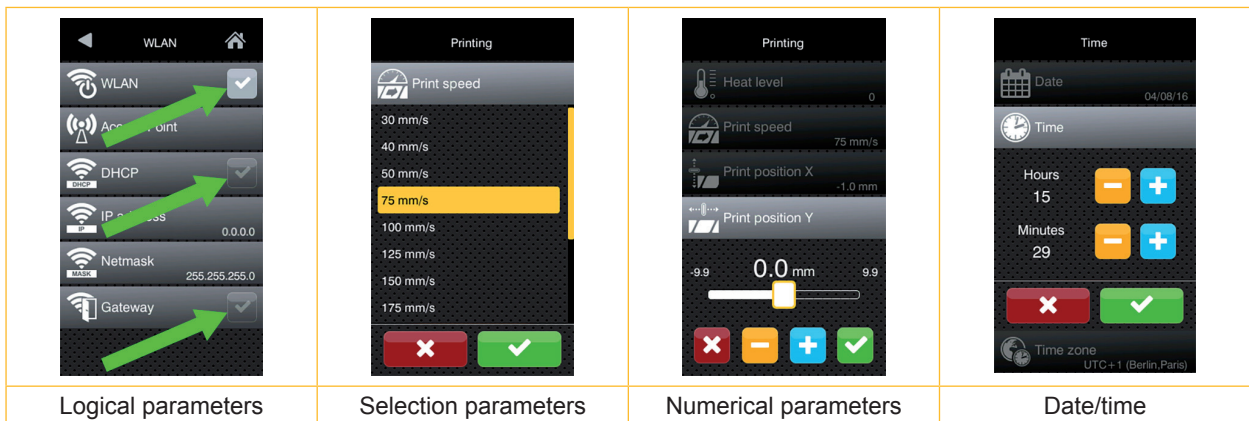

Figure 3 Samples for parameter setting







	Scroll bar for rough value setting
	Decreasing the value step-by-step
	Increasing the value step-by-step
	Return without saving the setting
	Return with saving the setting
	Parameter is disabled, touching enables the parameter
	Parameter is enabled, touching disables the parameter

Figure 4 Buttons for parameter setting

## 3 Menu

### 3.3 Service Key

A service key is required for accessing special service functions not accessible to the operator. This key switches the printer to service mode and enables:

- Access to additional configuration parameters
- Resetting of the service counter
- Additional information in the status print and in the device list
- Changing of the device name
- Access to PIN-protected configuration parameters and functions without entering the PIN
- Access to configuration parameters for optional assemblies, even if they are not currently installed

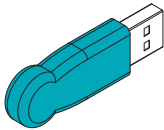

Figure 5 Service key



#### **Attention!**

**Incorrect settings and data loss via unauthorized access.**

**Access protection is deactivated when the service key is inserted. Operation of the printer by unauthorized persons can lead to incorrect settings and data loss in this case.**

- ▶ **Provide the service key to authorized persons only.**
- ▶ **Remove service key after service work and store it in a secure location.**

- ▶ Insert service key into a USB master interface of the printer.

The service key also can be inserted while the device is switched on.



#### **Notice!**

**In this document, parameters and functions which are only accessible when the service key is inserted are indicated using the following note:**

 **Access only with service key inserted!**

## 4 Info

The  *Info* function provides an overview of important status information on the display of the printer.

- ▶ Start menu.
- ▶ Select *Info*.
- ▶ Return with *Close*.

The following parameters are displayed:

Line	Meaning	Example
1	Printer type Version number and creation date of the firmware	<i>I7100-300</i> <i>Firmware V5.08</i> <i>July 28, 2017</i>
2	Serial number of the PCB CPU, Revision of PCB CPU and the FPGA	<i>PCB</i> <i>S/N 164162031171</i> <i>PCB Rev. 0</i> <i>FPGA Rev. 12</i>
3	Operative time and number of printed labels	<i>Hours/no. of labels</i> <i>814h/5177</i> <i>686h/3984 (Service)</i>
4	Previously printed paper lengths with thermal direct printing / thermal transfer printing	<i>Thermo/Transfer</i> <i>4.35m/277.65m</i> <i>0.08m/248.52m (Service)</i>
5	IPv4 address of the printer when connected to a network via Ethernet MAC address of the network adapter on the PCB CPU	<i>Ethernet</i> <i>IPv4 192.168.9.10</i> <i>MAC 70:82:0e:99:91:63</i>
6	IPv4 address of the printer when connected to a network via Wi-Fi MAC address of the Wi-Fi adapter	<i>Wi-Fi</i> <i>IPv4 172.20.200.63</i> <i>MAC e8:4e:06:37:59:30</i>
7	Zeroconf host name	<i>mDNS</i> <i>cab-999163.local</i>
8	Resolution, number of dots and revision of the printhead	<i>TPH</i> <i>300dpi, 1248dots</i> <i>Rev. 2.0.0</i>

Table 3 *Info* display

## 5 Security

In the  *Security* menu the access rights for several printer function can be set.

- ▶ Start menu.
- ▶ Select *Security*.









Parameter	Meaning	Default
 PIN protection	Password to protect certain parameters and functions accessible by the control panel.	0000
 Password ftpprint	Password for FTP printing ▶ Login as ftpprint Access only when <i>Interfaces &gt; Network services &gt; FTP = "On"</i>	print
 Password ftpcard	Password for FTP access to storage devices (USB stick, SD card, IFFS) ▶ Login as ftpcard Access only when <i>Interfaces &gt; Network services &gt; FTP = "On"</i>	card
 Password ftpadmin	Password for FTP firmware update ▶ Login as ftpadmin Access only when <i>Interfaces &gt; Network services &gt; FTP = "On"</i>	admin
 Password website	Password for Parameter setting via web interface ▶ Login as admin Access only when <i>Interfaces &gt; Network services &gt; Website = "On"</i>	admin
 Security web service	Authentication type for the SOAP protocol Access only when <i>Interfaces &gt; Network services &gt; Web service = "On"</i>	Digest
 Password web service	Password for the SOAP protocol Access only when <i>Interfaces &gt; Network services &gt; Web service = "On"</i>	soap
 Password VNC	Password for the VNC server Access only when <i>Interfaces &gt; Network services &gt; VNC server = "On"</i>	vnc

Table 4 Parameters of the *Security* menu

## 6 Configuration

### 6.1 Configuration via Control Panel

A host of parameters for configuring the printer are found in the *Setup* menu.

- ▶ Configure the printer via the control panel during initial commissioning and when making major changes to the operational conditions.
- ▶ For changes required for processing different print jobs use software settings.









#### Notice!

The *Setup* menu can be protected from unauthorized access via a code number (PIN).

#### 6.1.1 Printing

- ▶ Start menu.
- ▶ Select *Setup > Printing*.

Parameter	Meaning	Default
 <i>Heat level</i>	<p>Heating value for compensating for the differing thermal behavior of print-heads. Changing this value is then especially necessary if the printing intensity has changed after replacing the printhead.</p> <ul style="list-style-type: none"> <li>▶ To adapt the printing intensity when using different media, print speeds or printing contents, you should change the heat level in the software.</li> </ul> <p>The settings of configuration and software are added together. The <i>Heat level</i> setting also affects the test printouts.</p>	0
 <i>Print speed</i>	<p>Basic print speed setting.</p> <p>The print speed can be re-specified for each print job via software. The basic setting is not changed by this.</p> <p>The print speed setting also affects the test printouts.</p>	50 mm/s
 <i>Print position X</i>	<p>Shifting of the entire print image perpendicular to the direction of paper flow.</p> <p>The absolute shifting is limited by the margins of the print zone. Those are determined by the width of the printing line on the printhead.</p> <p>The setting can also be adjusted by the software.</p> <p>The settings of configuration and software are added together.</p>	0.0 mm
 <i>Print position Y</i>	<p>Shifting of the entire print image in the direction of paper flow. With positive values, printing begins later in the direction of paper flow.</p> <p>Shifting of the print image in the direction of paper flow also influences the peel and cut positions.</p> <ul style="list-style-type: none"> <li>▶ Correct the <i>Peel position</i> and <i>Cut position</i> parameters by the same value in the opposite direction.</li> </ul> <p>The setting can also be adjusted by the software.</p> <p>The settings of configuration and software are added together.</p>	0.0 mm
 <i>Backfeed</i>	<p>Method for backfeeding the label medium.</p> <p>Backfeeding is necessary in the cutting and peel-off modes since a label is pushed out passed the front edge of the next label above the print line when peeling off/cutting.</p> <p><i>always:</i> Backfeeding occurs independently of label contents.</p> <p><i>smart:</i> Backfeeding only occurs when the next label is not yet completely prepared when peeling off/cutting the current label. Otherwise, the second label is pushed on and completed after removal of the first label without backfeeding.</p>	smart
 <i>Backfeed position</i>	<p>Offset of the backfeed movement</p>	1.0 mm

## 6 Configuration







Parameter	Meaning	Default
 <i>Print on demand</i>	<p>Peel-off mode : Behavior after removing a label from the peel position  <i>On:</i> The next label will be printed and peeled-off after touching </p> <p><i>Off:</i> The next label will be printed and peeled-off immediately</p> <p>Cut mode : Behavior between the cuts  <i>On:</i> After cutting the next label will be printed and cut after touching </p> <p><i>Off:</i> All labels will be printed and cut nonstop</p>	<i>Aus</i>
 <i>Reprint</i>	<p>Printing of another label with the information of the previous print job by touching .</p> <p>This function can be executed until the print buffer is cleared with .</p> <p><i>Re-render:</i> Adaption of counter values, variable data can be newly put in.  <i>Duplicate:</i> New label is identical with the last label of the print job.  <i>Off:</i> No reprint</p>	<i>Re-render</i>
 <i>Length Scale</i>	Eliminate deviations of the print length from the length set in the programming	<i>0,0%</i>

Table 5 Parameters of the *Setup > Printing* menu

### 6.1.2 Labels

- ▶ Start menu.
- ▶ Select *Setup > Labels*.



Parameter	Meaning	Default
 <i>Label sensor</i>	<p>Method for detecting the starting end of the label.</p> <p><i>Gap Sensor:</i> Detection using changes in the transparency between the label and label gap. <i>Bottom-Reflect:</i> Detection using reflex marks on the bottom of the medium. <i>Continuous label media:</i> Checking the existence of media only.</p>	<i>Gap sensor</i>
 <i>Extrapolate labels</i>	The positions of the labels which are between the label sensor and the printhead are calculated from the first label recognized by the sensor and the programmed label distance. That way those labels can be printed although the printhead previously was open.	<i>Off</i>

Table 6 Parameters of the *Setup > Labels* menu

### 6.1.3 Ribbon

- ▶ Start menu.
- ▶ Select *Setup > Ribbon*.





Parameter	Meaning	Default
 <i>Transfer print</i>	<p><i>On:</i> Sensor for monitoring the transfer ribbon is activated.  <i>Off:</i> Sensor for monitoring the transfer ribbon is not activated.</p> <p>The setting can be overwritten for each print job via software. The basic setting is not changed by this.</p>	<i>On</i>
 <i>Warn level ribbon</i>	Threshold diameter (32–74 mm) of the ribbon supply roll, if the value is undershot the "ribbon low" message will be activated	<i>Off</i>
 <i>Pause on warning</i>	The print job will be interrupted when the "ribbon low" message appears	<i>Off</i>
 <i>Monitor ink side</i>	Setting of the ribbon unwinding direction. The print job will be interrupted when the wrong ribbon winding direction has been detected. The error message "Ribbon ink side" appears.	<i>Off</i>

Table 7 Parameters of the *Setup > Ribbon* menu

## 6 Configuration

### 6.1.4 Tearing-off

- ▶ Start menu.
- ▶ Select *Setup > Tearing-off*.



Parameter	Meaning	Default
 <i>Tear-off mode</i>	Positioning the label medium for tearing off at the tear-off plate. <i>On:</i> Additional advancement of the label medium which positions the label gap after the last printed label at the dispense plate. <i>Off:</i> Label advance stops once the last label has fully passed the print line.	<i>Ein</i>
 <i>Tear-off position</i>	Shifting of the tear-off position in the direction of paper flow. With positive values, the label strip is transported farther out of the printer.	<i>0.0 mm</i>

Table 8 Parameters of the *Setup > Tearing-off* menu

### 6.1.5 Cutting

\*  If cutter is not installed, access only with service key inserted.

- ▶ Start menu.
- ▶ Select *Setup > Cutting*.



Parameter	Meaning	Default
 <i>Cut position</i>	Offset of the cut position relative to the rear label edge. The setting can also be adjusted by the software. The settings of configuration and software are added together.	<i>0.0 mm</i>
 <i>Perforation level</i>	<b>with perforation cutter only</b> Setting of the perforation depth. The setting can also be adjusted by the software. The settings of configuration and software are added together.	<i>0</i>

Table 9 Parameters of the *Setup > Cutting* menu

### 6.1.6 Peeling-off

\*  If peel-off module is not installed, access only with service key inserted.

- ▶ Start menu.
- ▶ Select *Setup > Peeling-off*.



Parameter	Meaning	Default
 <i>Peel-off position</i>	Shift the position of the dispensed label relative to the dispensing edge. The setting can also be adjusted by the software. The settings of configuration and software are added together.	<i>0.0 mm</i>
 <i>Backfeed delay</i>	Delay time between removing the label from the peel position and the backfeed of the label.	<i>250 ms</i>

Table 10 Parameters of the *Setup > Peeling-off* menu



## 6 Configuration

### 6.1.7 Labelling

\*  If applicator is not installed, access only with service key inserted.

- ▶ Start menu.
- ▶ Select *Setup > Labelling*.













Parameter	Meaning	Default
 <i>Transfer mode</i>	Setting the operation mode <i>Stamp on, Roll on, Blow on</i>	<i>Stamp on</i>
 <i>Cycle sequence</i>	Setting the application mode <i>Print-Apply / Apply-Print</i> <i>Print-Apply:</i> An external start signal releases the print of a label and following the application of the label. After a cycle is complete, the pad without label waits in the start position. <i>Apply-Print:</i> An extra signal starts the print of the first label and the transfer of the label to the pad. The external start signal releases the application of the label and following the print and transfer of the next label. After a cycle is complete, the pad with a label is in the waiting position.	<i>Print-Apply</i>
 <i>Waiting position</i>	<i>up:</i> Pad waits in the start position for the start signal <i>down:</i> Pad waits in the labelling position for the start signal Only at <i>Transfer mode = Blow on</i> and <i>Cycle sequence = Apply-Print</i>	<i>up</i>
 <i>Blow time</i>	Switch-on time (max. 2,5 s) of the blowing air for the label transfer Only at <i>Transfer mode = Blow on</i>	<i>1000 ms</i>
 <i>Roll-on time</i>	Dwell time (max. 5 s) of the pad in the labelling position Only at <i>Transfer mode = Roll on</i>	<i>1000 ms</i>
 <i>Support delay on</i>	Setting the switch-on delay (max. 2,5 s) for the supporting air between print start and switching on the supporting air. The delay prevents swirling at the front of the label and, consequently, avoids faults when the label is being picked up from the printer.	<i>0 ms</i>
 <i>Support delay off</i>	Setting the switch-off delay (max. 2,5 s) for the supporting air between the end of label forwarding and switching on the supporting air. The delay can be useful to separate the rear edge of the label from the carrier to avoid errors and to improve the accuracy of label positioning	<i>0 ms</i>
 <i>Start delay</i>	Delay (max. 2,5 s) between start signal and the start of an labelling cycle. Allows e.g. the use of product sensors at conveyors.	<i>0 ms</i>
 <i>Lock time</i>	All start signals coming in following the first start signal are ignored when they arrive within the lock time (max. 2,5 s).	<i>0 ms</i>
 <i>Vacuum delay</i>	<i>On</i> - The vacuum will be switched on after the label feed is completed. <i>Off</i> - The vacuum will be switched on when the label feed starts.	<i>Off</i>
 <i>Vacuum control</i>	Setting the label transfer check from printer to pad and from pad to product by the vacuum sensor	<i>On</i>
 <i>Peel-off position</i>	Shift the position of the dispensed label relative to the dispensing edge. The setting can also be adjusted by the software. The settings of configuration and software are added together.	<i>0.0 mm</i>

Table 11 Parameters of the *Setup > Labelling* menu

## 6 Configuration

### 6.1.8 Interfaces

- ▶ Start menu.
- ▶ Select *Setup > Interfaces*.

#### Ethernet







Parameter	Meaning	Default
 <i>Hostname</i>	Unique identification of the printer in a network in a human readable format	<i>generated of OEM name and the last six digits of the MAC address</i>
 <i>DHCP</i>	Method of issuing IP address <i>On</i> : Dynamic issuing of IP address by the DHCP server <i>Off</i> : Direct issuing of the IP address by the operator	<i>On</i>
 <i>&gt; IP address</i>	IP address of the label printer. Only valid with <i>DHCP = Off</i> .	-
 <i>&gt; Netmask</i>	Subnet mask (classification and address range) of the local network. Only valid with <i>DHCP = Off</i> .	-
 <i>&gt; Gateway</i>	Connection address between the local network and other networks.	<i>Off</i>
 <i>&gt;&gt; Gateway address</i>	The IP address of the computer (router) on the network through which the connection can be established is used for this. The address of the router can also be issued via DHCP.	-
 <i>&gt; DNS-Server</i>	Setting the IP address of a DNS server manually The DNS server resolves the internet addresses to IP addresses e.g. to select network services such as NTP per domain name.	-

Table 12 Parameters of the *Setup > Interfaces > Ethernet* menu

#### WLAN









Parameter	Meaning	Default
 <i>WLAN</i>	Activation of the WLAN interface	<i>Off</i>
 <i>&gt; Access-Point</i>	Selection of the Access Point to setting up the WLAN connection.	-
 <i>&gt; DHCP</i>	▷ <i>Ethernet &gt; DHCP</i>	<i>On</i>
 <i>&gt;&gt; IP address</i>	▷ <i>Ethernet &gt; IP address</i>	-
 <i>&gt;&gt; Netmask</i>	▷ <i>Ethernet &gt; Netmask</i>	-
 <i>&gt;&gt; Gateway</i>	▷ <i>Ethernet &gt; Gateway</i>	<i>Off</i>
 <i>&gt;&gt;&gt; Gateway address</i>	▷ <i>Ethernet &gt; Gateway address</i>	-
 <i>&gt; DNS-Server</i>	▷ <i>Ethernet &gt; DNS-Server</i>	-

Table 13 Parameters of the *Setup > Interfaces > WLAN* menu

## 6 Configuration



### Network Services

Parameter	Meaning	Default
<i>FTP</i>	Activation of the File Transfer Protocol	<i>On</i>
<i>LPD</i>	Activation of the network printing service LPD	<i>On</i>
<i>RawIP</i>	Activation of the network printing service RawIP and selection of the port address	<i>9100</i>
<i>Website</i>	Activation of the Hypertext Transfer Protocol for the access to the internal printer website	<i>On</i>
<i>Web service</i>	Activation of the Simple Object Access Protocol	<i>Off</i>
<i>SNMP</i>	Data exchange between printer and management station via Simple Network Management Protocol	<i>Off</i>
<i>&gt; SNMP community</i>	Keyword to assign the SNMP rights	<i>public</i>
<i>VNC server</i>	Activation of the VNC server for remote access to the control panel	<i>Off</i>
<i>Zeroconf</i>	Activation of the auto-configuring Zeroconf method for adhoc networks	<i>Off</i>

Table 14 Parameters of the *Setup > Interfaces > Network services* menu



### RS-232

Parameter	Meaning	Default
<i>Baud rate</i>	Speed (in Baud) of data transfer	<i>115.200</i>
<i>Handshake</i>	Data transfer protocol	<i>RTS/CTS</i>

Table 15 Parameters of the *Setup > Interfaces > RS-232* menu

## 6 Configuration



Parameter	Meaning	Default
<i>START mode</i>	<p>Configuration of the I/O signal START</p> <p><i>Edge:</i> A label will be printed by switching on 24V between START and GND_EXT.</p> <p><i>Level:</i> In <b>Rewind mode</b> labels are printed as long as 24V are switched on between START and GND_EXT.</p> <p>In <b>Peel-off mode</b> a label will be printed after receiving the signal LBLREM as long as 24V are switched on between START and GND_EXT.</p>	<i>Edge</i>
<i>REPRINT mode</i>	<p>Configuration of the I/O signal REPRINT</p> <p><i>Edge:</i> A label will be repeated by switching on 24V between REPRINT and GND_EXT.</p> <p><i>Level:</i> A label will be repeated as long as 24V are switched on between REPRINT and GND_EXT.</p> <p><i>START/REPRINT select:</i> A label will be repeated when 24V are switched on between REPEAT and GND_EXT and the START signal will be activated additionally.</p>	<i>Edge</i>
<i>Automatic LBLREM</i>	<p>Simulation of the I/O signal LBLREM</p> <p>For peel-off mode without present sensor</p> <p><i>On:</i> With the signal START the removing of the previous label also will be confirmed.</p> <p><i>Off:</i> To confirm the label removing the signal LBLREM must be activated.</p>	<i>Off</i>

Table 16 Parameters of the *Setup > Interfaces > I/O* menu

### 6.1.9 Errors

- ▶ Start menu.
- ▶ Select *Setup > Errors*.

Parameter	Meaning	Default
<i>Error-Reprint</i>	<p><i>On:</i> With a correctable error and corresponding troubleshooting, the label being printed when the error occurs is repeated.</p> <p><i>Off:</i> Print job is continued with the next label.</p>	<i>On</i>
<i>Syntax error</i>	Printer switches to error mode after receipt of an incorrect command.	<i>On</i>
<i>Barcode error</i>	<p><i>On:</i> With faulty barcode contents or size specifications, printing is interrupted.</p> <p><i>Off:</i> Printing is not interrupted if an error occurs. If barcode contents are faulty, the printer attempts to replace the incorrect data with valid characters (e.g. zeros). If barcode size specifications are faulty, a gray area is printed instead of the barcode.</p>	<i>On</i>
<i>Network error</i>	Printer switches to error mode when problems with the network connection occur.	<i>Off</i>

Table 17 Parameters of the *Setup > Errors* menu

## 6 Configuration

### 6.1.10 Region

- ▶ Start menu.
- ▶ Select *Setup > Region*.



Parameter	Meaning	Default
 <i>Language</i>	Setting the display language	<i>English</i>
 <i>Country</i>	Setting the country-specific date and time formats. The time formats can also be overwritten via software. The changes are not saved permanently, however.	<i>Germany</i>
 <i>Keyboard</i>	Setting of the keyboard layout when using an external keyboard or the soft keyboard on the printer display.	<i>Automatic (=Country)</i>

Table 18 Parameters of the *Setup > Region* menu

### 6.1.11 Time

- ▶ Start menu.
- ▶ Select *Setup > Time*.







Parameter	Meaning	Default
 <i>Date</i>	Setting of the system date in the format DD.MM.YYYY. The print output of the date occurs in the format set via the <i>Country</i> parameter. The date can also be changed via software. The change is not saved permanently, however.	-
 <i>Time</i>	Setting the system time in the HH:MM:SS format. When changing the time, ensure that the <i>Timezone</i> , <i>Daylight saving</i> and <i>Date</i> parameters are set correctly. The time can also be synchronized automatically via the internet using the Ethernet interface. The print output of the time occurs in the format set via the <i>Country</i> parameter. The time can also be changed via software. The change is not saved permanently, however.	-
 <i>Time zone</i>	Adaptation of the time display of the printer to the time zone in relation to UTC (Universal Time Coordinated).	<i>UTC+1</i>
 <i>Daylight saving</i>	Selection of the daylight saving regulation applicable for the region. The time is then changed automatically.	<i>EU</i>
 <i>Time synchronisation</i>	Activation of a service to synchronize date and time of the printer.	<i>NTP</i>
 <i>&gt; Time server</i>	Address of the time server	

Table 19 Parameters of the *Setup > Time* menu

## 6 Configuration

### 6.1.12 Display

- ▶ Start menu.
- ▶ Select *Setup > Display*.



Parameter	Meaning	Default
 <i>Orientation</i>	Adaptation of the display contents to the display orientation.	0°
 <i>Brightness</i>	Brightness of the LCD display.	8
 <i>Time powersave</i>	Time between the last operation and activation of energy-saving mode.	5 min

Table 20 Parameters of the *Setup > Display* menu

### 6.1.13 Interpreter

- ▶ Start menu.
- ▶ Select *Setup > Interpreter*.







Parameter	Meaning	Default
 <i>Character set</i>	Selection of the character set table for adaptation to the computer system used. Switching the character set via software is not possible. Characters not available in the selected character set can be accessed using the Unicode table.	UTF-8
 <i>USB</i>	Choosing between the programming languages JScript and ZPL for data transfer via USB interface	JScript
 <i>RS-232</i>	Choosing between the programming languages JScript and ZPL for data transfer via RS-232 interface	JScript
 <i>FTP</i>	Choosing between the programming languages JScript and ZPL for data transfer via FTP	JScript
 <i>LPD</i>	Choosing between the programming languages JScript and ZPL for printing with LPD	JScript
 <i>RawIP</i>	Choosing between the programming languages JScript and ZPL for printing with RawIP	JScript
 <i>Bluetooth</i>	Choosing between the programming languages JScript and ZPL for data transfer via Bluetooth * only with Bluetooth adapter installed	JScript

Table 21 Parameters of the *Setup > Interpreter* menu

### 6.1.14 ZPL

- ▶ Start menu.
- ▶ Select *Setup > ZPL*.



Parameter	Meaning	Default
 <i>&gt; Printing width</i>	Setting the print width for ZPL programming	100.0 mm
 <i>&gt; Label length</i>	Setting the label length for ZPL programming	150.0 mm

Table 22 Parameters of the *Setup > ZPL* menu

## 6 Configuration

### 6.2 Configuration via the Web Interface

The parameters accessible via the control panel can also be set via the web interface contained in the firmware of the printer.

The printer web interface can be accessed with a browser (e.g. Microsoft Internet Explorer, Mozilla Firefox) with JavaScript activated via the Ethernet interface or the optional WLAN interface.

#### Calling Up the Web Interface



#### **Attention!**

**Whenever settings are changed via the web interface you are requested to enter the user name "admin" and a password. The default value of the password is also "admin". The password can be changed via the web interface (▷ "Setup Tab" page 26).**

- ▶ Start the browser.
- ▶ Call the web interface by entering the IP address via HTTP (e.g. `http://192.168.100.208`).  
The "Status" tab is open on the home screen.

The web interface contains the following tabs:

- Status: general status description ▷ page 24.
- Setup: configuration parameter settings ▷ page 25.
- Security: password settings ▷ page 26.
- Devices: list of the hardware and optional components ▷ page 27.
- Fonts: overview of the available fonts ▷ page 27.

## 6 Configuration

### 6.2.1 Status Tab

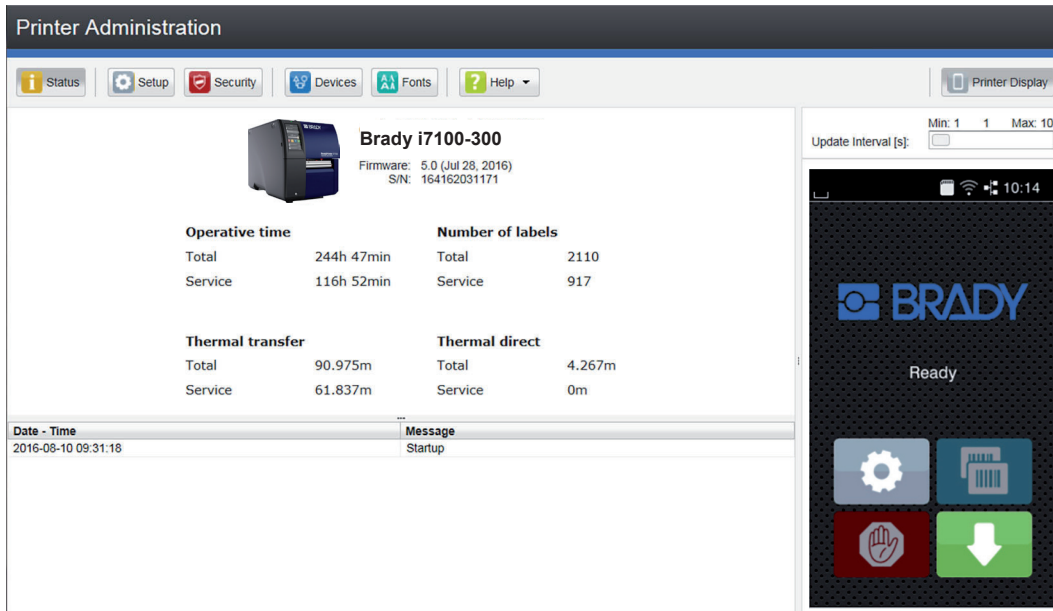

Figure 6 "Status" tab on the printer web interface

The following information is contained in the left top section of the "Status" tab:

- Printer type
- Firmware version
- Serial number of the PCB CPU
- Operative time of the printer
- Number of labels printed since commissioning
- Previously printed paper length with thermal transfer printing
- Previously printed paper length with thermal direct printing

A list of the events which have occurred since the printer was switched on is to be found in the left bottom section of the tab.

The right section of the tab shows the current printer display information.



**Notice!**

By clicking the buttons the printer can be operated in the same manner as by using the touchscreen on the device.

When the printer display is selected by mouse click, it is possible to use the computer keyboard in the same manner like an External Keyboard (▷ "15.3" on page 24) e.g. for entering variable input data.



## 6 Configuration

### 6.2.2 Setup Tab

On the "Setup" tab all the configuration parameters can be set which are also accessible via the control panel in the Setup menu.

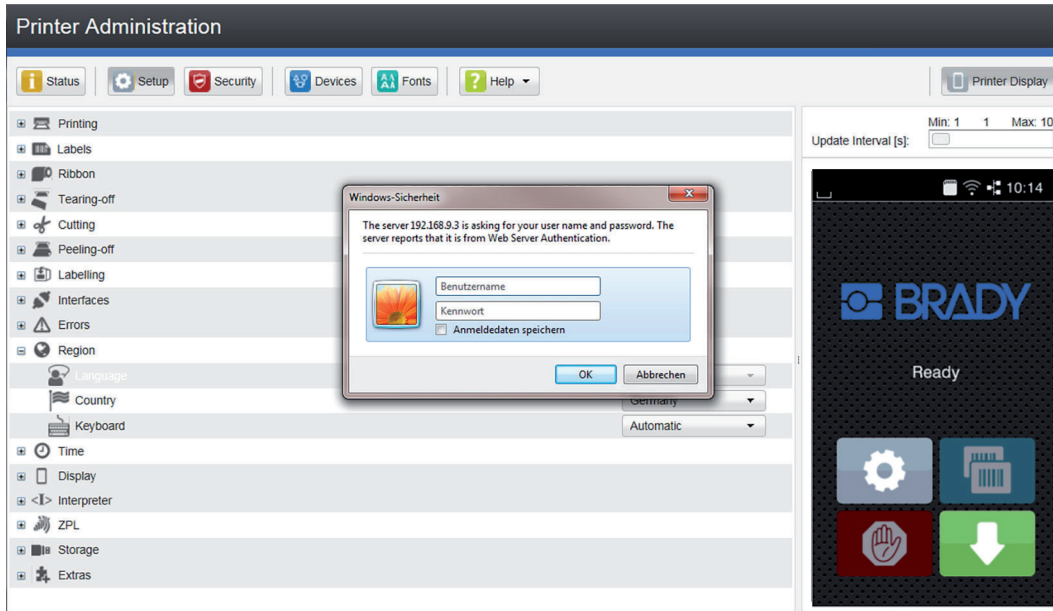

Figure 7 "Setup" tab on the printer web interface

To change a parameter:

1. Locate parameter in the tree structure.
2. Set the value of the parameter at the right end of the concerning line.  
A prompt to enter user name and password appears ▷ page 13.
3. Enter user name and password and click **OK**.

## 6 Configuration

### 6.2.3 Security Tab

On the "Security" tab the access rights for several printer function can be set.

The tab contains the same parameters as the *Security* menu of the Setup ▷ page 13.

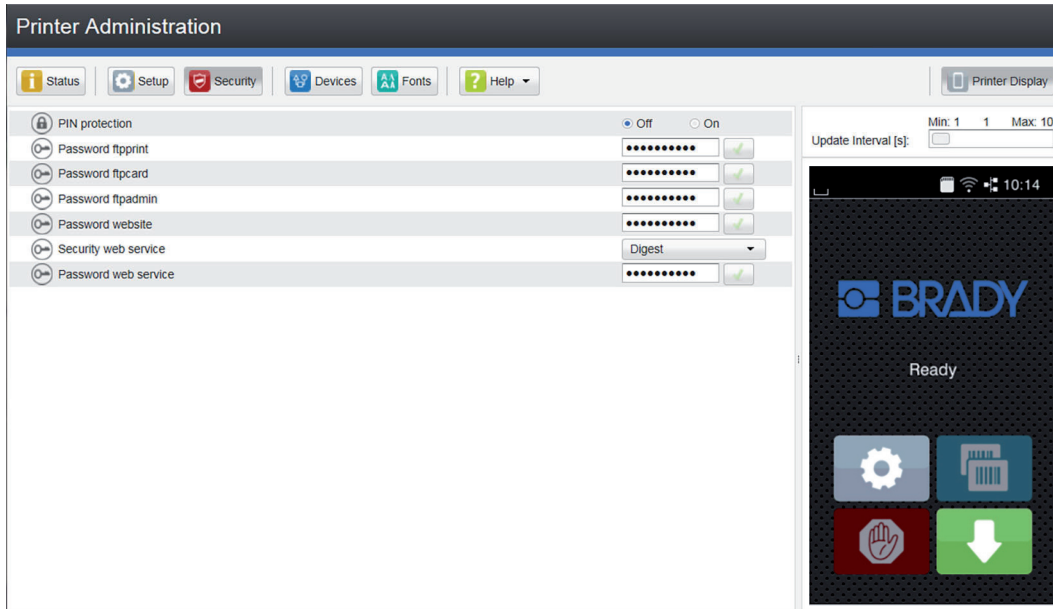

Figure 8 "Security" tab on the printer web interface

To change a parameter:

1. Locate parameter in the tree structure.
2. Set the value of the parameter at the right end of the concerning line.  
A prompt to enter user name and password appears ▷ page 13.
3. Enter user name and password and click **OK**.

## 6 Configuration

### 6.2.4 Devices Tab

The "Devices" tab provides an overview of the most important hardware components installed in the printer and the optional devices connected.

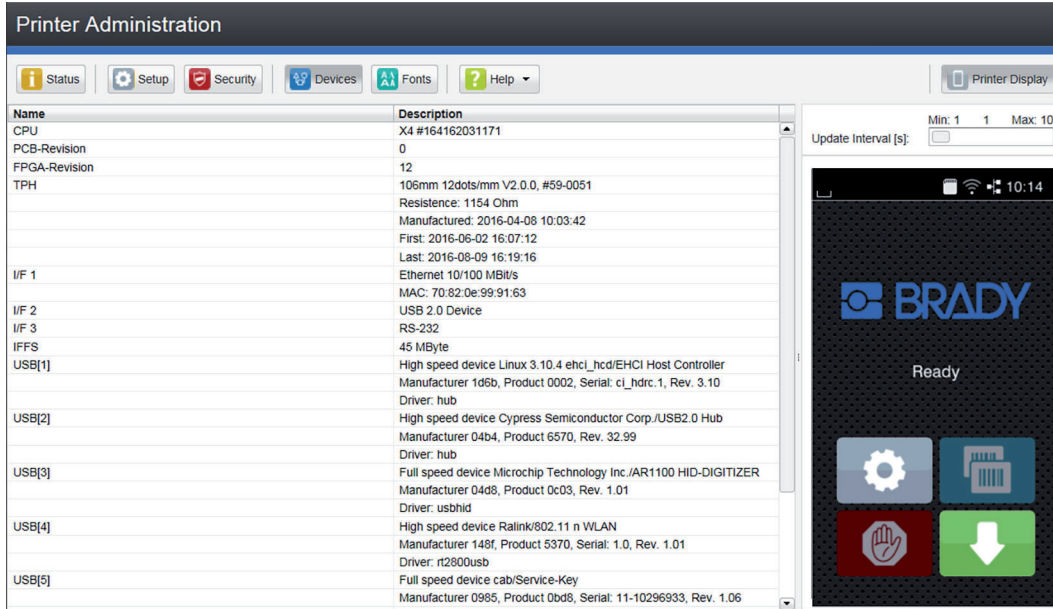

Figure 9 "Devices" tab on the printer web interface

The contents of the display correspond with those of the *Device list* ▷ "Table 24" on page 31.

### 6.2.5 Fonts Tab

The most important parameters of the fonts available in the printer are listed on the "Fonts" tab. The table contains both the original fonts in the printer and other fonts loaded into the printer.

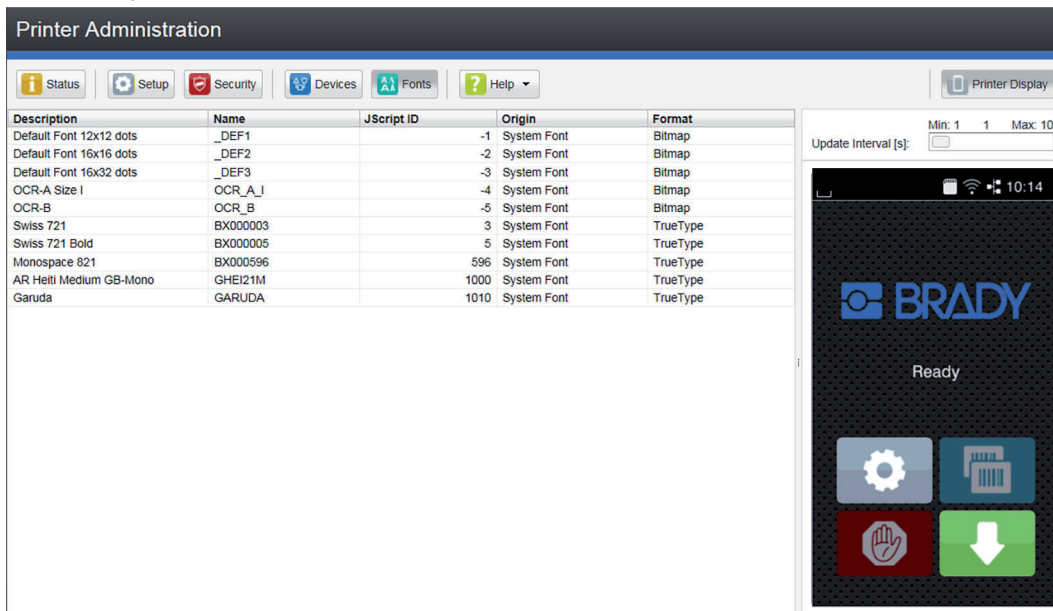



Figure 10 "Fonts" tab on the printer web interface

The parameters correspond to those in the *Font list* ▷ "Table 23" on page 30.



## 7 Test Functions

### 7.1 Overview

The  *Test* menu contains test functions providing information on:

- the most important configuration parameters
- the fonts available in the printer
- important hardware components and connected peripheral devices
- the print image quality and state of the thermal printhead
- available WLAN networks.

### 7.2 Status Print

The *Status print* function prints a test image containing information on the configuration and status of the printer. The printout occurs using the heat level and print speed specified in the *Setup > Printing* menu.



#### Notice!

**The printout occurs without taking the label gaps into consideration. This is why continuous label media is most suitable for this purpose.**

- ▶ Insert printable medium (labels, continuous label media) which extends across the entire printing width.
- ▶ If the printout is to occur using thermal transfer printing, insert transfer ribbon with the maximum width.
- ▶ Start menu.
- ▶ Select *Test > Status print*.

The printout can be canceled with .





















Status print	
Fri Aug 4 08:02:16 2017 cab SQUIX 4/300MP Firmware V5.08 (Jul 28, 2017) - #164162031171	
 <b>Printing</b>	Heat level 0 Print speed 75 mm/s Print position X 0,0 mm Print position Y 0,0 mm Backfeed smart Backfeed position 1,0 mm Print on demand Off Reprint Re-render Length scale 0,0 %
 <b>Labels</b>	Label sensor Gap Extrapolate labels Off
 <b>Ribbon</b>	Transfer print On Warn level ribbon 32 mm Pause on warning Off Monitor ink side Off
 <b>Tearing-off</b>	Tear-off mode On Tear-off position 0,0 mm
 <b>Cutting</b>	Cut position 0,0 mm Perforation level 0
 <b>Peeling-off</b>	Peel-off position 0,0 mm Backfeed delay 250 ms
 <b>Labelling</b>	Transfer mode Stamp on Cycle sequence Print-Apply Waiting position up Blow time 1000 ms Roll-on time 1000 ms Support delay on 0 ms Support delay off 0 ms Start delay 0 ms Lock time 0 ms Vacuum delay On Vacuum control On Peel-off position 0,0 mm
 <b>Interfaces</b>	Ethernet Hostname cab-999163 DHCP Off IP address 192.168.9.13 Netmask 255.255.255.0 Gateway Off DNS server 0.0.0.0
 <b>Wi-Fi</b>	Wi-Fi On Access Point calbgast DHCP Off IP address 172.20.200.93 Netmask 255.255.255.0 Gateway Off DNS server 0.0.0.0
 <b>Network services</b>	FTP On LPD On RawIP 9100 Website On Web service On SNMP On SNMP community public Zeroconf On Time service NTP Time server 0.0.0.0
 <b>RS-232</b>	Baud rate 115200 Handshake RTS/CTS
 <b>Errors</b>	Error-Reprint On Syntax error On Barcode error On Network error On
 <b>Region</b>	Language English Country Germany Keyboard Automatic
 <b>Time</b>	Date 04.08.2017 Time 08:02:16 Time zone UTC+1 (Berlin,Paris) Daylight saving EU Time synchronization NTP Time server
 <b>Display</b>	Orientation 0° Brightness 8 Time powersave 5 min
 <b>Interpreter</b>	Character set UTF-8 USB JScript RS-232 JScript FTP JScript LPD JScript RawIP JScript Bluetooth JScript
 <b>ZPL</b>	Print width 100,0 mm Label length 150,0 mm
 <b>Storage</b>	Default storage SD Card
 <b>Security</b>	PIN protection On
 <b>Extras</b>	Cleaning interval 1000 m
 <b>Printer Info</b>	Operative time Total 821h 57min Service 684h 02min Number of labels Total 5182 Service 3989 Thermal transfer Total 281,292 m Service 252,154 m Thermal direct Total 4,347 m Service 0,080 m Cleaning interval 1000 m TPH temperature 24,8 °C Heat voltage 23,8 V TPH heat level statistics < 0 0,000 m 0-7 281,292 m 8-14 0,000 m > 14 0,000 m

Figure 12 Status print. Parameters marked *italic* are only printed when the printer is equipped with the respective optional assembly or when the service key is inserted

## 7 Test Functions

### 7.3 Font list

The *Font list* function prints the most important parameters of the fonts available in the printer in tabular form. The table contains both the original fonts in the printer and other fonts loaded into the printer. The printout occurs using the heat level and print speed specified in the *Setup > Printing* menu.



**Notice!**

**The printout occurs without taking the label gaps into consideration. This is why continuous label media is most suitable for this purpose.**

- ▶ Insert printable medium (labels, continuous label media) which extends across the entire printing width.
- ▶ If the printout is to occur using thermal transfer printing, insert transfer ribbon with the maximum width.
- ▶ Start menu.
- ▶ Select *Test > Font list*.

The printout can be canceled with  .

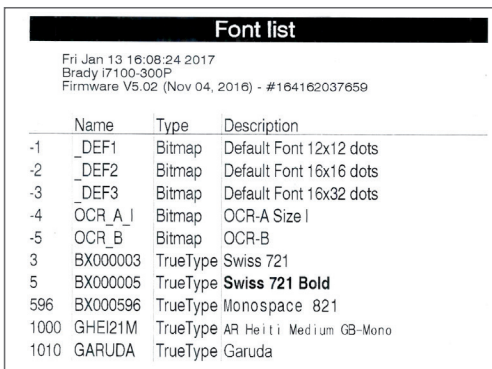

Font list		
Fri Jan 13 16:08:24 2017		
Brady I7100-300P		
Firmware V5.02 (Nov 04, 2016) - #164162037659		
Name	Type	Description
-1 _DEF1	Bitmap	Default Font 12x12 dots
-2 _DEF2	Bitmap	Default Font 16x16 dots
-3 _DEF3	Bitmap	Default Font 16x32 dots
-4 OCR_A_I	Bitmap	OCR-A Size I
-5 OCR_B	Bitmap	OCR-B
3 BX000003	TrueType	Swiss 721
5 BX000005	TrueType	<b>Swiss 721 Bold</b>
596 BX000596	TrueType	Monospace 821
1000 GHEI21M	TrueType	AR Heiti Medium GB-Mono
1010 GARUDA	TrueType	Garuda

Figure 13 Font list

Column	Meaning
No.	ID number of the font required for programming (command T).
Name	Name with which the font is saved internally.
Type	Type of font generation. It provides information on the variability of the font and is important when programming (command T).
Description	Explanations of the font: size, font family. The printout occurs in the appropriate font.

Table 23 Parameters of the *Font list*

## 7 Test Functions

### 7.4 Device List

The *Device list* function prints out the most important information on hardware components of the printer and connected devices. The printout occurs using the heat level and print speed specified in the *Setup > Printing* menu.



**Notice!**

**The printout occurs without taking the label gaps into consideration. This is why continuous label media is most suitable for this purpose.**

- ▶ Insert printable medium (labels, continuous label media) which extends across the entire printing width.
- ▶ If the printout is to occur using thermal transfer printing, insert transfer ribbon with the maximum width.
- ▶ Start menu.
- ▶ Select *Test > Device list*.

The printout can be canceled with .

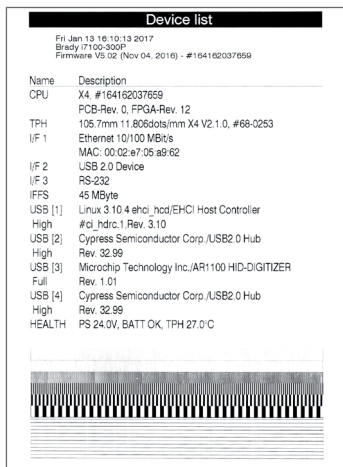

Figure 14 Device list  
Parameters marked *italic* are only printed when the service key is inserted

Name	Information
CPU	Type and serial number of the PCB CPU Revision of PCB CPU and FPGA
TPH	Print width and resolution of the installed thermal printhead
IF [x]	Type of interfaces installed <b>x</b> : Number of interface
IFFS	Size of the Internal Flash File System
USBMEM	Size and type of an installed USB storage device
SD	Size and type of an installed SD card
USB [a] Speed	Type and revision of installed USB devices <b>a</b> : number of USB device <b>Speed</b> : data transfer speed (low, full, high)  The following properties are only displayed when the service key is inserted: <b>Mfr.</b> : Manufacturer ID. This identifies the manufacturer of the USB device <b>Class</b> : Code for the USB device class <b>Protocol</b> : Code for the type of communication with the USB device <b>Phase</b> : Internal value for troubleshooting
HEALTH	Printhead voltage, charge state of the lithium battery on the PCB CPU, temperature of CPU and printhead
Line pattern	Lines differing in thickness at various distances. They are used to evaluate the print quality.

Table 24 Parameters of the *Device list*

## 7 Test Functions

### 7.5 Test Grid

The *Test grid* function prints out a geometric pattern on a background grid. This allows you to assess the evenness of the print quality.

The printout occurs using the heat level and print speed specified in the *Setup > Printing* menu.



#### Notice!

**The printout occurs without taking the label gaps into consideration. This is why continuous label media is most suitable for this purpose.**

- ▶ Insert printable medium (labels, continuous label media) which extends across the entire printing width.
- ▶ If the printout is to occur using thermal transfer printing, insert transfer ribbon with the maximum width.
- ▶ Start menu.
- ▶ Select *Test > Test grid*.

The geometric pattern is printed every 3 seconds once the Test grid function is started.

The printout can be canceled with

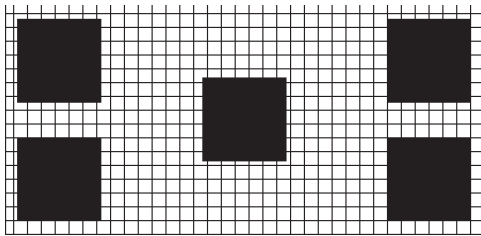

Figure 15 Test grid



## 7 Test Functions

### 7.6 WiFi Status

\* **Access only when WLAN is activated!**

The *WiFi status* function prints out a list with the most important parameters of the accessible Wireless Access Points. The printout occurs using the heat level and print speed specified in the *Setup > Printing* menu.



**Notice!**

**The printout occurs without taking the label gaps into consideration. This is why continuous label media is most suitable for this purpose.**

- ▶ Insert printable medium (labels, continuous label media) which extends across the entire printing width.
- ▶ If the printout is to occur using thermal transfer printing, insert transfer ribbon with the maximum width.
- ▶ Start menu.
- ▶ Select *Test > WiFi status*.

The printout can be canceled with  .

WiFi status			
Thu Aug 11 10:15:20 2016			
Brady i7100-300			
Firmware V5.00 (Jul 28, 2016) - #164162031171			
Channel	Name/BSS ID	Signal level	Security
1	default 00:24:b2:36:98:60	●●●●●	WPA2-PSK
1	brady-firma 00:24:b2:36:98:61	●●●●●	WPA2-PSK
1	brady-gast 00:24:b2:36:98:62	●●●●●	WPA2-PSK
11	default 00:24:b2:36:98:60	●○○○○	WPA2-PSK
11	brady-firma 00:24:b2:36:98:61	●○○○○	WPA2-PSK
11	brady-gast 00:24:b2:36:98:62	○○○○○	WPA2-PSK

Figure 16 WiFi status

The parameters have the following meaning :

Column	Meaning
Channel	Channel; frequency range of the Access Point
Name/BSS ID	Name of the wireless LAN MAC address of the Access Points
Signal level	Scale of the WiFi signal strength
Security	Type of data encryption

Table 25 Parameters of the *WiFi status*

## 8 Diagnostic Functions

The  *Diagnostics* menu contains several functions for troubleshooting

### 8.1 Printhead

The function *Printhead* provides an overview of important status information concerning the printhead on the display of the printer.

- ▶ Start menu.
- ▶ Select *Diagnostics > Printhead*.
- ▶ Return with *Close*.

The following parameters are displayed:

Line	Meaning	Example
1	Serial number of the printhead	<b>Serial no.</b> 59-0051
2	Part number of the printhead	<b>Part no.</b> 5977310
3	Firmware revision of the printhead	<b>Firmware</b> 2.0.0
4	Temperature of the printhead	<b>Temperature</b> 26.4 °C
5	Resolution of the printhead	<b>Resolution</b> 12 DPMM (dots/millimeter)
6	Print width / Number of dots	<b>Width/no. of dots</b> 106mm/1248
7	Operative time/Number of printed labels with the current printhead	<b>Hours/no. of labels</b> 773h/5354
8	Previously printed paper lengths with thermal direct printing / thermal transfer printing	<b>Thermal/Transfer</b> 4.35m/285.49m
9	Previously printed paper length with heat level < 0	<b>Heat level &lt;0</b> 0.00m
10	Previously printed paper length with heat level 0 - 7	<b>Heat level 0-7</b> 289.84m
11	Previously printed paper length with heat level 8 - 14	<b>Heat level 8-14</b> 0.00m
12	Previously printed paper length with heat level > 14	<b>Heat level &gt;14</b> 0.00m
13	Resistance of the printhead	<b>Resistance</b> 1154Ω
14	Description of the printhead	<b>Description</b> 105.7mm 11.806dots/mm X4

Table 26 *Printhead display*

## 8 Diagnostic Functions

The  *Diagnostics* menu contains several functions for troubleshooting

### 8.2 ASCII Dump Mode

*ASCII Dump Mode* offers the option of checking incoming control sequences at an interface. The commands are printed out as text. In addition, a corresponding error message is printed out immediately after an error occurs.

The printout occurs using the heat level and print speed specified in the *Setup > Printing* menu.



**Notice!**

The printout occurs without taking the label gaps into consideration. This is why continuous label media is most suitable for this purpose.



**Notice!**

In case of questions about programming, keep a printout of your label file which was created in *ASCII Dump Mode* handy. The printout can be transmitted clearly via fax.

- ▶ Insert printable medium (labels, continuous label media) which extends across the entire printing width.
- ▶ If the printout is to occur using thermal transfer printing, insert transfer ribbon with the maximum width.
- ▶ Start menu.
- ▶ Select *Diagnostics > ASCII Dump Mode*.
- ▶ Send print jobs.
- ▶ Select  to cancel the printout or switch to the *Ready* mode.

**Example:**

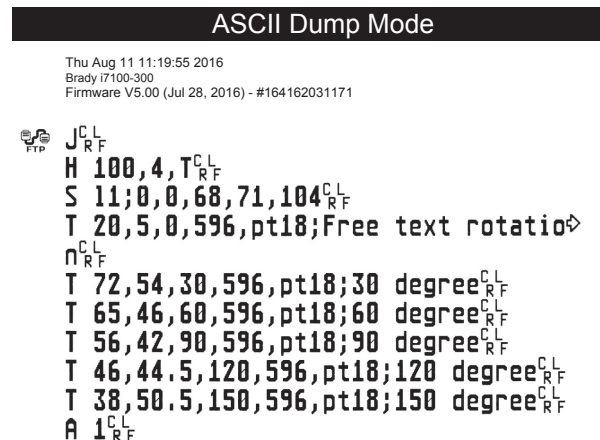
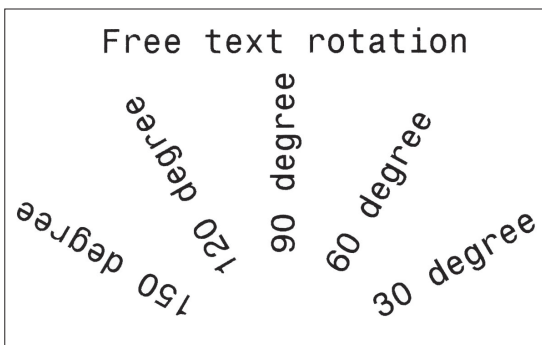

Figure 17 Example label printed normally (left) and in *ASCII dump mode* (right)

The control characters (ASCII-Code 00...31) are presented in stylized design.

- e.g. :  $L_F$  : Code 10 (0A) - line feed  
 $C_R$  : Code 13 (0D) - carriage return

## 8 Diagnostic Functions

### 8.3 Label Profile

The *Label profile* function carries out a longer label advance. It saves the values measured by the label sensor here and then prints them out in a diagram.

The printout is used to check label detection in conjunction with the optical properties of the label medium. The printout occurs using the heat level and print speed specified in the *Setup > Printing* menu.



#### Notice!

**The printout occurs without taking the label gaps into consideration. This is why continuous label media is most suitable for this purpose.**

- ▶ Select the label sensor to be tested in the *Setup > Labels* menu ▷ page 15.
- ▶ Load the label medium to be tested into the printer.
- ▶ Start menu.
- ▶ Select *Diagnostics > Label profile*.

The printer performs a longer label advance. The label sensor measures the transparency/reflection capacity of the label material here. The message *Insert* appears in the display once the advance is complete.

- ▶ Insert printable medium (labels, continuous label media) which extends across the entire printing width.
- ▶ If the printout is to occur using thermal transfer printing, insert transfer ribbon with the maximum width.
- ▶ Start the diagram printout with *Continue*.

The printout can be canceled with .

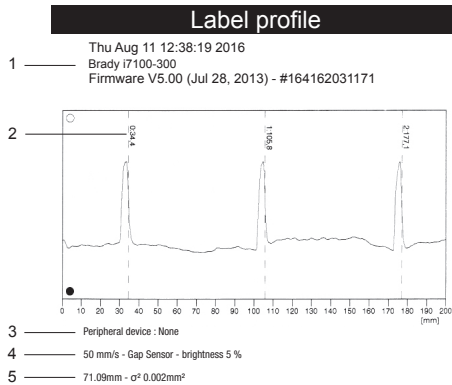

Figure 18 Label profile

No.	Information
1	Date and time of the printout Device type Version and creation date of the firmware Serial number of the PCB CPU Firmware version and serial number of the label sensor
2	Coordinate in the direction of paper flow at which the label start was detected
3	Type of peripheral device connected
4	Print speed, method of label detection (Gap sensor / Bottom-reflect sensor) Brightness of the sensor LED during the measurement
5	Average value and variation of label distances

Table 27 Information in *Label profile*

## 8 Diagnostic Functions

### 8.4 Event Log

The label printer saves the following events in the *Event log*:

- Hardware fault
- Printhead replacement
- Firmware updates
- Changing the OEM name
- Resetting of the service counters

The printout occurs using the heat level and print speed specified in the *Setup > Printing* menu.



#### Notice!

**The printout occurs without taking the label gaps into consideration. This is why continuous label media is most suitable for this purpose.**

- ▶ Insert printable medium (labels, continuous label media) which extends across the entire printing width.
- ▶ If the printout is to occur using thermal transfer printing, insert transfer ribbon with the maximum width.
- ▶ Start menu.
- ▶ Select *Diagnostics > Event log*.

Event log	
Thu Aug 11 14:04:15 2016	
Brady 17100-300	
Firmware V5.00 (Jul 28, 2016) - #164162031171	
Date	Description
30.06.16 07:45	TPH (#59-0051) -> 300 dpi, 1248 dots
30.06.16 07:46	Firmware update -> V5.00 (0000)
12.07.16 07:38	Firmware update -> V5.00 (0000)
13.07.16 13:35	Printer Model: Brady 17100-300
02.08.16 14:01	Firmware update -> V5.00 (0000)
05.08.16 11:38	Clear service counters
05.08.16 11:38	Cleaning interval -> 41242 + 1000000

Figure 19 Event log

## 8 Diagnostic Functions

### 8.5 Save Data Stream

**\* Access only with external storage device!**

The function *Save data stream* allows to store data incoming via an interface as an .lbl file to an external storage device (SD card, USB memory module) installed on the printer.

- ▶ Insert SD card or USB memory module.
- ▶ Start menu.
- ▶ Select *Diagnostics > Save data stream*.
- ▶ Select the external storage device.
- ▶ Enter a file name.

The predefined name is composed of the identifier "log", date, clock time and the suffix ".lbl", but may also be altered. Confirm the selection with .

- ▶ In the status line of the display the data saving is indicated by the symbol .
- ▶ Send print jobs. All data received by the printer are stored in the .lbl file.
- ▶ To complete the function select *Diagnostics > Save data stream* again and confirm with *OK*. The .lbl file will be stored in the root of the storage device.

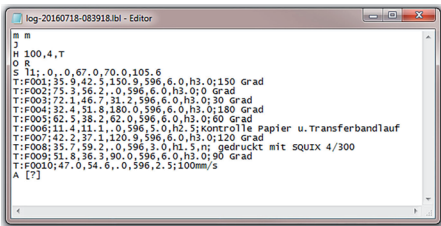

Figure 20 Saved data stream

### 8.6 Save Print Image

**\* Access only with external storage device!**

The function *Save print image* allows to store the last print image as a .png file to an external storage device (SD card, USB memory module) installed on the printer.

- ▶ Insert SD card or USB memory module.
- ▶ Start menu.
- ▶ Select *Diagnostics > Save print image*.
- ▶ Select the external storage device.
- ▶ Enter a file name.

The predefined name is composed of the identifier "img", date, clock time and the suffix ".png", but may also be altered.

- ▶ Confirm the selection with . The .png file will be stored in the root of the storage device.

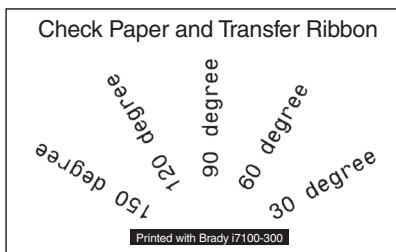



Figure 21 Saved print image

## 8 Diagnostic Functions

### 8.7 Save System Log

**\* Access only with external storage device!**

The function *Save system log* allows to store several system files packed to a .zip file to an external storage device (SD card, USB memory module) installed on the printer.

- ▶ Insert SD card or USB memory module.
- ▶ Start menu.
- ▶ Select *Diagnostics > Save system log*.
- ▶ Select the external storage device.
- ▶ Enter a file name.  
The predefined name is composed of the identifier "sys", date, clock time and the suffix ".png", but may also be altered.
- ▶ Confirm the selection with  . The display shows the several steps of saving.

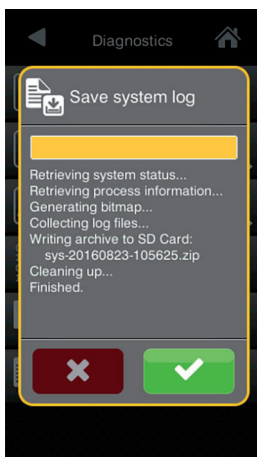

Figure 22 System log saving

- ▶ Confirm the completion of saving with  . The .zip file will be stored in the root of the storage device.

## 9 Extras

### 9.1 Firmware Update



#### Notice!

The firmware file can be obtained from the internet.

#### \* Access only with external storage device!

- ▶ Copy the firmware file to the "misc" directory of the storage device. This can be done on a computer or via FTP on the printer.
- ▶ Insert the prepared storage device into the printer.
- ▶ Start menu.
- ▶ Select *Extras*.  
If the menu is protected via a PIN a prompt appears in the display. Enter the code number and confirm it.
- ▶ Select *Firmware update*.  
The display shows the selection of external storage devices and the firmware files stored on the devices.
- ▶ Select a file and confirm with  .  
The selected firmware file is copied. A progress indicator is displayed while the firmware is being copied. After completion the printer will be re-started.



#### Notice!

The firmware update also can be done via FTP printer management ▷ "13.4" on page 55.

### 9.2 Save Settings

With the *Save settings* function the printer configuration can be saved to a storage device.

- ▶ Start menu.
- ▶ Select *Extras*.  
If the menu is protected via a PIN a prompt appears in the display. Enter the code number and confirm it.
- ▶ Select *Save settings*.
- ▶ Select the external storage device.
- ▶ Enter a file name.  
The predefined name is composed of the identifier "gui", date, clock time and the suffix ".xml", but may also be altered.
- ▶ Confirm the selection with  . The .xml file will be stored in the folder /misc of the storage device.

An error message appearing during the saving procedure may be caused by an unreadable medium (e.g. unknown medium, unformatted medium) ▷ "14.5.4" on page 58.



## 9 Extras

### 9.3 Load Settings

A printer configuration previously saved to a storage device can be loaded with the *Load settings* function.

- ▶ Start menu.
- ▶ Select *Extras*.  
If the menu is protected via a PIN a prompt appears in the display. Enter the code number and confirm it.
- ▶ Select *Load settings*.
- ▶ Select the desired file.
- ▶ Confirm the selection with . Loading of the configuration data starts. Do not remove the USB flash drive until the loading procedure is complete. The printer returns to the *Extras* menu.

If an error occurs during the loading procedure, an error message appears in the display. Restart the loading procedure in this case. If an error occurs again, the configuration parameters must be entered via the control panel.

### 9.4 Reset Settings

With the *Default settings* function all setup parameters excepting the passwords ▷ page 13 can be reset to the default values.

- ▶ Start menu.
- ▶ Select *Extras*.  
If the menu is protected via a PIN a prompt appears in the display. Enter the code number and confirm it.
- ▶ Select *Reset settings*.  
The display shows "Reset settings".
- ▶ Select *Continue*. The setup parameters will be reset and printer returns to the *Extras* menu.

### 9.5 Reset Passwords

The function *Reset passwords* allows to reset all passwords for the network services to the default values.

- ▶ Start menu.
- ▶ Select *Extras*.  
If the menu is protected via a PIN a prompt appears in the display. Enter the code number and confirm it.
- ▶ Select *Reset passwords*.  
The display shows "Reset passwords".
- ▶ Select *Continue*. The passwords will be reset and printer returns to the *Extras* menu.

Function	User name	Password
Web interface access	admin	admin
FTP printing	ftpprint	print
FTP access to storage devices	ftpcard	card
FTP firmware update	ftpadmin	admin
Web service	soap	soap

Table 28 Default passwords

## 9 Extras

### 9.6 Cleaning Interval

With the parameter *Cleaning interval* an interval for the printhead cleaning can be set in steps of 100 m media passage. If the set length of the medium (label strip, transfer ribbon) has passed the printhead and an error occurs in the flow of the medium (e.g. label end, transfer ribbon end), the *Clean printhead!* message appears in the display.

The error message for the error which occurred is not displayed until the *Clean printhead!* message is acknowledged. As long as no errors occur in the medium flow, no messages are displayed and the print job is continued even if the cleaning interval has passed.

- ▶ Start menu.
- ▶ Select *Extras*.  
If the menu is protected via a PIN a prompt appears in the display. Enter the code number and confirm it.
- ▶ Select *Cleaning interval*.
- ▶ Select a new value and confirm the selection with .

### 9.7 Legal Notices

The *Legal notices* function shows the licenses and software libraries of third party solutions used in the printer firmware.

- ▶ Start menu.
- ▶ Select *Extras*.  
If the menu is protected via a PIN a prompt appears in the display. Enter the code number and confirm it.
- ▶ Select *Legal notices*.  
The notices will be shown on the display
- ▶ Select *Close* to leave the notices.

## 10 Help

The *Help* menu contains video clips about important operations.  
 (Contact Brady Tech Support to check availability of Help Clips Videos for your individual printer)

- ▶ Start menu.
- ▶ Select *Help*.  
A list of clips will be shown.
- ▶ Select a clip.  
The playback of the clip will start.

The playback can be controlled by buttons:





	Leave current clip, return to clip selection
	Pause playback
	Start playback
	Stop playback, return to start

Figure 23 Buttons for playback control

## 11 Service Functions

### 11.1 Reset Service Counter

 **Access only with service key inserted!**

The printer has total and service counters.

- Total counter: The total counter contains the values for the entire service life of the printer up to now. The values of the total counter are displayed in the *Info* menu and in the *Status print*.
- Service counter: The service counter can be reset after more substantial maintenance or repair work with the service key inserted. Here, it provides information on the printing output since the last reset. The values of the service counter are displayed in the *Status print*.

The following data is recorded in both counters:

Data	Description
Operative time	Printer switch-on time
Number of labels	Number of labels printed
Transfer printing	Length of medium printed with transfer printing
Thermal printing	Length of medium printed with thermal direct printing

Table 29 Total and service counter data

- ▶ Insert service key into an USB master interface.
- ▶ Start menu.
- ▶ Select *Service > Reset service counter*.  
The display shows *Reset service counter*.
- ▶ Select *Continue*. The data recorded by the service counter is set to the value 0.

The status print can be used to check whether the values were reset.

### 11.2 Calibrate Label Sensor

 **Access only with service key inserted!**

With the *Calibrate label sensor* function label sensor can be adjusted. This is necessary if sensor itself or CPU PCB has been changed.

- ▶ Insert service key into an USB master interface.
- ▶ Start menu.
- ▶ Select *Service > Calibrate label sensor*.  
The display shows *Remove labels*.
- ▶ Remove labels and transfer ribbon from the printer.
- ▶ Select *Continue*.  
If the calibration was successful the message *Sensor successfully calibrated* appears.
- ▶ Confirm the completion with *Close*.

## 11 Service Functions

### 11.3 Printhead Zero Position X

 **Access only with service key inserted!**

The purpose of the *Printhead zero pos. X* setting is to fundamentally align the printing image to the printhead perpendicular to the printing direction in order to compensate for printhead tolerances.

1. Determine the deviation of the actual from theoretical position of the printing image perpendicular to the printing direction.
2. Select menu *Service > Printhead zero pos. X*.
3. Choose a setting that counteracts deviation.

### 11.4 Printhead Zero Position Y

 **Access only with service key inserted!**

The purpose of the *Printhead zero pos. Y* setting is to fundamentally align the printing image to the printhead in the printing direction in order to compensate for printhead tolerances.

1. Determine the deviation of the actual from theoretical position of the printing image in the printing direction.
2. Select menu *Service > Printhead zero pos. Y*.
3. Choose a setting that counteracts deviation.

### 11.5 Printer Model

 **Access only with service key inserted!**

With the *Printer model* function the firmware can be adapted to the device type.

- ▶ Start menu.
- ▶ Select *Service > Printer Model*.
- ▶ Select a model.

Following the *Info* function, all test prints and the web interface show the selected prucker model.

## 12 I/O Interface

For use in a network the printer is equipped with an I/O interface.

### 12.1 Pin Assignment

The interface has a 25 pin SUB-D connector.

Figure 24 I/O interface

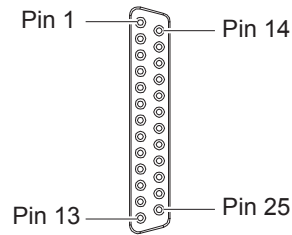

**Note!** The function of the outputs on the pins 4, 9 10 and 21 can be re-defined temporarily by direct programming e.g. to control external devices with the user bits 0 to 3 ▷ [Programming Manual](#).

Pin	Signal	Name	Description	Activation / Active State
1	⊖	FSTLBL	Print first label only for <i>Cycle sequence = Apply-Print</i>	+24 V between Pin 1 and Pin 25
2	-	-	Do not use	
3	⊕	ENDPOS	Applicator is in the position of transferring the label onto the product.	+24 V on Pin 3
4	⊕	FEEDON	Media transport ON Labels are fed by the printer	+24 V on Pin 4
		Bit 0	User Bit 0 is set	
5	⊕	HOMEPOS	Applicator is in the position where the label is taken up from the printer.	+24 V on Pin 5
6		GND_INT	Ground (0 V) for sensors or trigger switches	
7	-	-	Do not use	
8	-	-	Do not use	
9	⊕	JOBRDY	Print job ready Print jobs are stored in the print module.	+24 V on Pin 9
		Bit 1	User Bit 1 is set	
10	⊕	READY	Printer is ready	+24 V on Pin 10
		Bit 2	User Bit 2 is set	
11	-	-	Do not use	
12	⊖	REPRINT	The last printed label will be repeated.	+24 V between Pin 12 and Pin 25
13	⊖	START	Print start signal only for <i>Print on demand = On</i>	+24 V between Pin 13 and Pin 25
14	⊖	PAUSE	Pause ON/OFF	Pause ON when +24 V between Pin 14 and Pin 25
15	⊕	RIBWARN	Warning end of ribbon The ribbon supply roll diameter has undershot a predefined level	0 V on Pin 15
16	⊖	LBLREM	Label removed For peel-off mode only. Confirmation of the superior control that the label has been taken from the peel-off position. Required for the validity of a new start signal.	Switch on +24 V between Pin 16 and Pin 25
17	⊖	JOBDEL	Cancel print job The current print job is canceled and deleted from the print buffer.	Switch on +24 V between Pin 17 and Pin 25
18	⊖	RSTERR	Reset Error state of the printer will be reset.	Switch on +24 V between Pin 18 and Pin 25
19		P24_INT	Internal operating voltage +24 V, Si T 100mA for external consumers e.g. sensors, trigger switches	
20		P24_EXT	External operating voltage +24 V	

## 12 I/O Interface

Pin	Signal	Name	Description	Activation / Active State
21		PEELPOS	Label in peel-off position For peel-off mode only. A label is in peel-off position.	+24 V on Pin 21
		Bit 3	User Bit 3 is set	
22		ERROR	General error message The operation will be stopped and the error type will be displayed.	0 V on Pin 22
23		STOP	Stop signal to interrupt the operation	Switch on +24 V between Pin 23 and Pin 25
24	-	-	Do not use	
25		GND_EXT	Ground of the external 24 V	

Table 30 Pin assignment of the I/O interface

### 12.2 Circuit Diagram of Inputs and Outputs

#### Digital Inputs

- conform to IEC/EN 61131-2 (Type 3)
- Operating voltage: 24 V DC (9.6..35 V)
- Switching logic: PNP switching
- Low level „0“: < 7 V DC
- High level „1“: > 11 V DC
- Input current per channel: 1,5..2,5 mA (at 24 V DC)
- Reverse polarity protection: yes
- ESD protection: conform to IEC/EN 6100-4-4

#### Digital Outputs

- conform to IEC/EN 61131-2
- Operating voltage: 24 V DC (11..35 V)
- Switching logic: PNP switching
- Output current per channel: 625 mA (overload protection)
- Short-circuit protection: yes
- Reverse polarity protection: yes
- ESD protection: conform to IEC/EN 6100-4-4

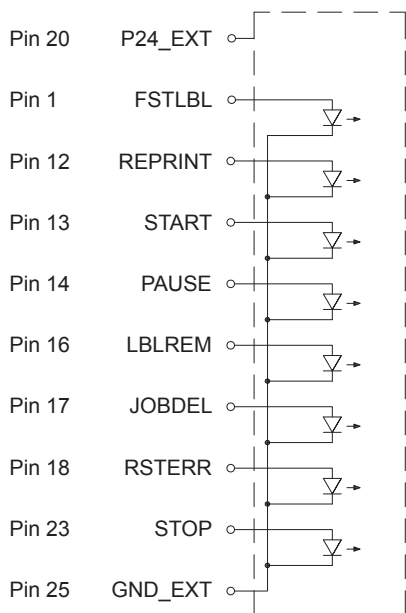

Figure 25 Connecting inputs

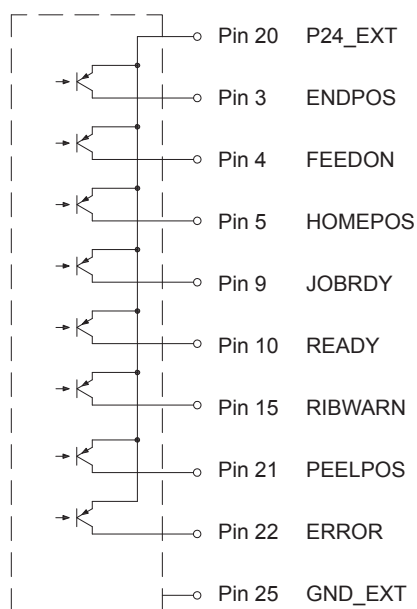

Figure 26 Connecting outputs

## 12 I/O Interface

### 12.3 Solution Examples

#### 12.3.1 Peeling-off on Demand with Present Sensor

In the standard peel-off mode a label will be printed immediately after the previous label has been taken from the peel position.

Using the I/O interface the print of the next label can be triggered by an external signal.

Requirements:

- Operation with Present Sensor PS800 (Brady part #149072), PS900 (Brady part #149075) or PS1000
- External circuit as shown in Figure 27.
- Setting *Printing > Print on Demand = "On"*.

Operation:

- ▶ Send a print job.
- ▶ Activate **START**.  
The first label will be printed and transported to the peel position.
- ▶ Remove the label.
- ▶ Activate **START** to start the next cycle.

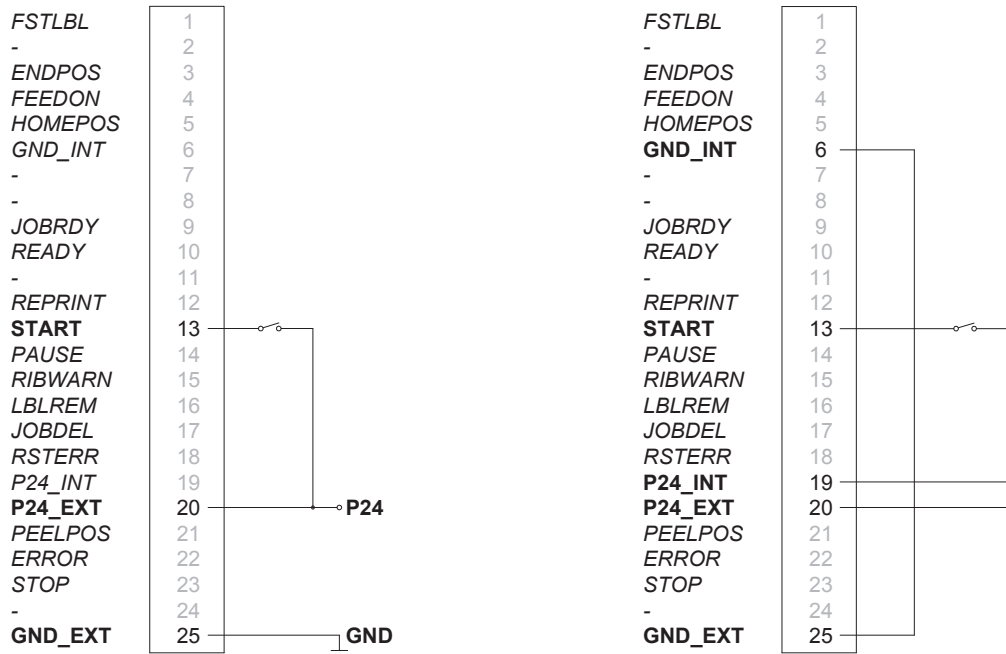

Operation with external voltage supply

Operation using the internal voltage

Figure 27 External circuit for peeling-off on demand with Present Sensor PS800 (Brady part #149072) or PS900 (Brady part #149075).



## 12 I/O Interface

### 12.3.2 Peeling-off on Demand without Present Sensor

In the peel-off mode with PS800 (Brady part #149072) or PS900 (Brady part #149075) the label removal from the peel position is detected by an optical sensor (see page 48).

This section describes using the I/O interface whereby the label removal can be confirmed by the external signal **LBLREM**, making it possible to operate the printer in peel-off mode without present sensor.

#### Starting Print and Confirming Label Removal with Two Signals

Requirements:

- Operation without present sensor.
- External circuit as shown in Figure 28
- Setting *Printing > Print on Demand* = "On".
- Setting *Interfaces > I/O > Automatic LBLREM* = "Off"

Operation:

- ▶ Send a print job.
- ▶ Activate **START**.  
The first label will be printed and transported to the peel position.
- ▶ Remove the label.
- ▶ Confirm the label removal with signal **LBLREM**.
- ▶ Activate **START** to start the next cycle.

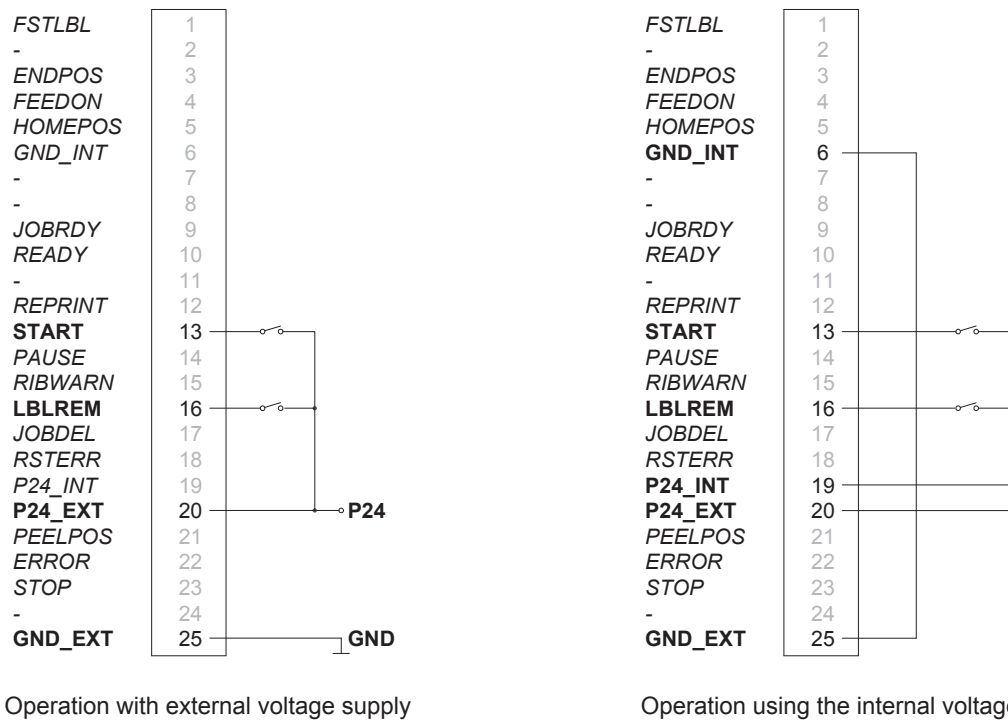

Figure 28 External circuit for peeling-off on demand without present sensor with two signals

## 12 I/O Interface

### Starting Print and Confirming Label Removal with Signal LBLREM

Requirements:

- Operation without present sensor.
- External circuit as shown in Figure 29.
- Setting *Printing > Print on Demand* = "On".
- Setting *Interfaces > I/O > START mode* = "Level".
- Setting *Interfaces > I/O > Automatic LBLREM* = "Off".

Operation:

- ▶ Hold signal **START** permanently active.
- ▶ Send a print job.  
The first label will be printed and transported to the peel position.
- ▶ Remove the label.
- ▶ Confirm the label removal with signal **LBLREM**.  
The next cycle will be started.

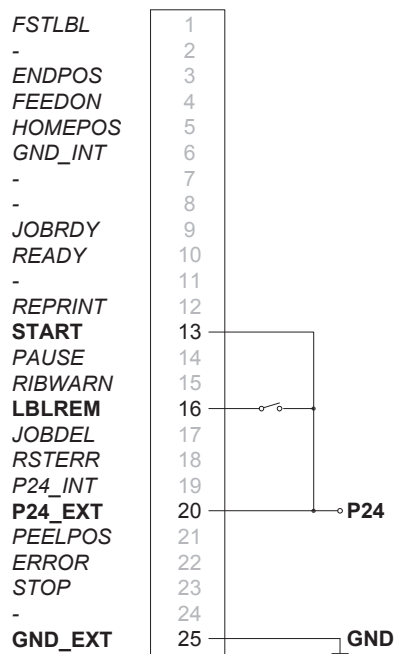

Operation with external voltage supply

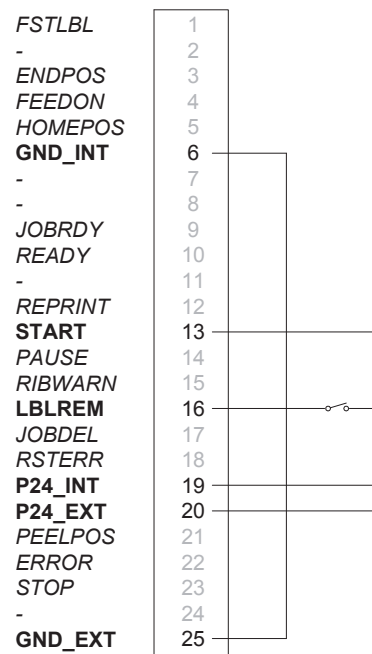

Operation using the internal voltage

Figure 29 External circuit for peeling-off on demand without present sensor with switching signal LBLREM

## 12 I/O Interface

### Starting Print and Confirming Label Removal with Signal START

Requirements:

- Operation without present sensor.
- External circuit as shown in Figure 30
- Setting *Printing > Print on Demand* = "On".
- Setting *Interfaces > I/O > START mode* = "Level".
- Setting *Interfaces > I/O > Automatic LBLREM* = "On".

Operation:

- ▶ Send a print job.
- ▶ Activate **START** and hold it active.  
The first label will be printed and transported to the peel position.
- ▶ Remove the label.
- ▶ Confirm the label removal with deactivation of **START**.
- ▶ Activate **START** again to start the next cycle.

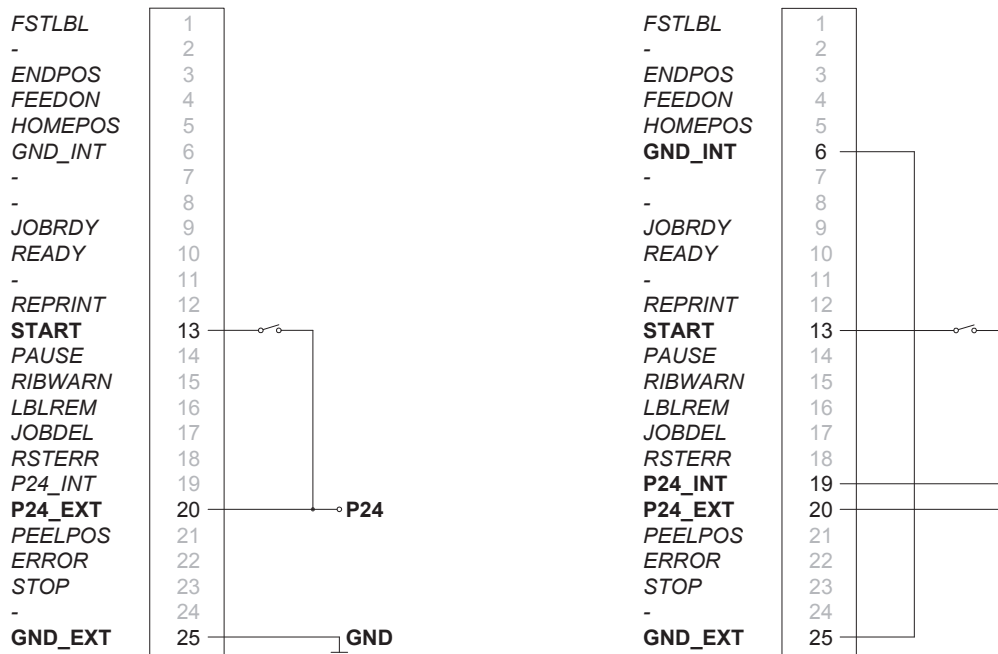

Operation with external voltage supply

Operation using the internal voltage

Figure 30 External circuit for peeling-off on demand without present sensor with switching signal START

## 12 I/O Interface

### 12.3.3 Cutting on Demand with Cutter

In the standard cut mode all labels of a print job will be printed and cut one after another without interruption. Using the I/O interface the print job can be split into single steps with printing and cutting each one label.

Requirements:

- Operation with Cutter CU400 (Brady part#149069).
- External circuit as shown in Figure 31.
- Setting *Printing > Print on Demand = "On"*.

Operation:

- ▶ Send a print job.
- ▶ Activate **START**.  
The first label will be printed and cut
- ▶ Activate **START** to start the next cycle.

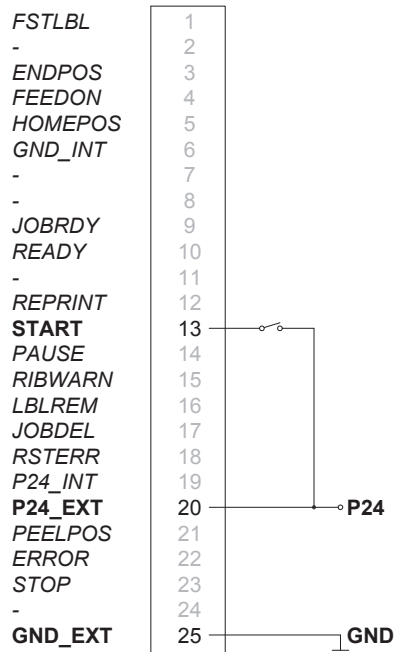

Operation with external voltage supply

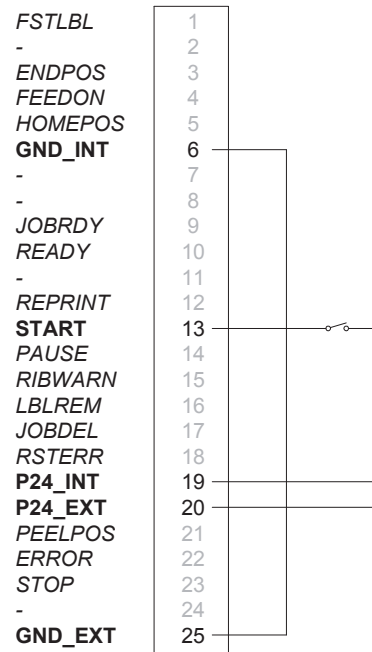

Operation using the internal voltage

Figure 31 External circuit for cutting on demand with Cutter CU400 (Brady part#149069)



**Notes!**

The function of the signal **START** can be released alternatively by pressing  on the touchscreen display.

## 12 I/O Interface

### 12.3.4 Pausing and Continuing a Print Job

In the standard operation without a peripheral device connected all labels of a print job will be printed without interruption.

To adapt the label output of the printer e.g. to an external device with a lower transport speed the print job can be interrupted meanwhile.

Requirements:

- Operation without peripheral device.
- External circuit as shown in Figure 32.
- Setting *Printing > Print on Demand* = "Off".

Operation:

- ▶ Send a print job.  
The labels of the print job will be printed one after the other.
- ▶ Activate the signal **PAUSE**.  
After completion of the current label the print job will be paused.
- ▶ Deactivate the signal **PAUSE**.  
The print job will be continued.

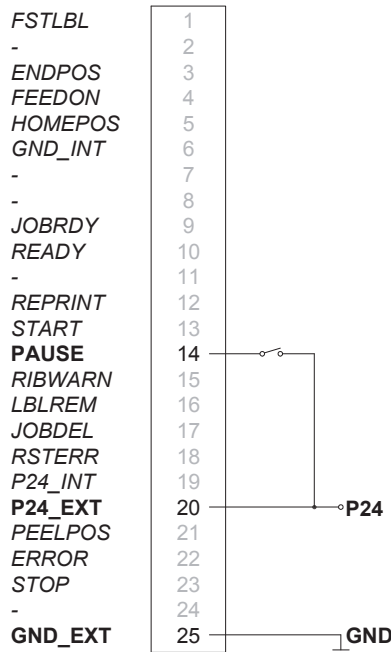

Operation with external voltage supply

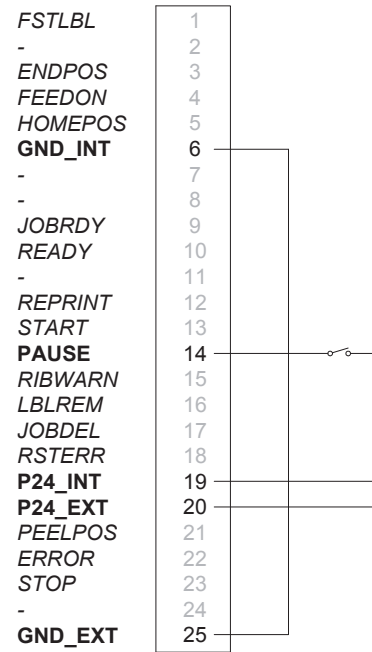

Operation using the internal voltage

Figure 32 External circuit for pausing and continuing a print job

## 13 FTP Printer Management

The File Transfer Protocol (FTP) allows to manage and transfer files on the network via the Ethernet interface or WLAN card. An FTP program (FTP client) is required which supports the "binary" transfer mode to manage the printer. The printer functions as an FTP server.

FTP printer management is comprised of four functions:

- Direct printing via copying JScript or ZPL files.
- Management of the memory media installed in the label printer
- IFFS management
- Firmware update.

### 13.1 FTP Login

To establish an FTP connection, the client must be logged on to the server. The login type depends on the client. The following information must be specified in any case, however:

- IP address of the label printer
- User name and password

Access to the printer management functions depends on the user name:

Function	User name	Default password
FTP printing, loading PPP vouchers	ftpprint	print
FTP access to storage devices	ftpcard	card
FTP firmware update	ftpadmin	admin

Table 31 Default passwords



#### Notice!

- ▶ **The passwords can be changed in the "Setup" tab of the web interface** ▶ page 26.

After logging on the FTP server is accessible in a manner similar to a Windows folder.

### 13.2 FTP Printing

Label files in cab JScript format (▶ Programming Manual) or in ZPL format can be printed directly via FTP connection:

- ▶ Establish a FTP connection with the user name **ftpprint** and the defined password (Default: **print**)  
An empty folder of the FTP server will be shown.
- ▶ Copy a label file in JScript or ZPL format to the folder of the FTP server.  
Printing of the label file is started immediately. The corresponding file is deleted once the print job is complete.
- ▶ Close the FTP connection.

### 13.3 FTP Access to Storage Devices

FTP connection allows to manage data of a storage device:

- ▶ Establish a FTP connection with the user name **ftpcard** and the defined password (Default: **card**).  
The content of the storage device will be shown. The files are separated into several subfolders.
- ▶ Manage the files as necessary. When copying files to the folder, type-based sorting occurs automatically in the subfolders.
- ▶ Close the FTP connection.

## 13 FTP Printer Management

### 13.4 FTP Firmware Update

FTP allows to carry out a firmware update:

- ▶ Establish a FTP connection with the user name **ftpadmin** and the defined password (Default: **admin**).  
An empty folder of the FTP server will be shown.
- ▶ Copy a valid firmware file (e.g. 500\_6714.cfw) to the folder.  
The status of the saving procedure is shown by a progress indicator in the display. The printer resets automatically after the update is carried out successfully.
- ▶ Close the FTP connection.

Whether the firmware update was carried out successfully can be checked on the "Status" tab of the web interface.

## 14 Storage Devices

Label descriptions, graphics, fonts, and database information can be saved for the long-term on memory media.



**Notice!**

- ▶ Always create a backup copy of external devices in case of a malfunction.

### 14.1 Suitable Storage Devices

**External Devices**

- USB flash drive at USB master interface.
- SD cards

**Internal Device**

- approx. 50 MB flash memory inside the printer (Internal Flash File System IFFS)

### 14.2 Installation

**\* For external storage devices only!**

- ▶ Slide SD card contact-side first into the matching slot until it latches. To unlatch SD card press it shortly into the slot and remove it.  
or
- ▶ Connect USB flash drive to an USB master interface.



**Attention!**

**Risk of data loss !**

- ▶ Do not remove the storage device while it is being accessed.

### 14.3 Directory Structure

On storage devices connected to the printer, the following directory structure is automatically generated when uploading files:

Folder name	Contents
fonts	Font files
images	Graphic files
labels	Label description files
misc	Firmware, PPP, Setup and TMP files

Table 32 Directory structure



## 14 Storage Devices

### 14.4 Writing

The storage devices can be written to in several ways. The most functionally secure way is writing to the storage device via a data interface.



#### Attention!

The device selected as *Default storage* is written to by default. To write to another device specify the path name of the device in the file name (▷ [Programming Manual](#)).

#### Example:

With direct programming, the command sequence for saving a label (file XYZ) has the following form:



Ms LBL; XYZ	Command for saving the file <b>XYZ</b>
J	
H 100,0,T	
S I1;0,0,68,71,104	Contents of the file <b>XYZ</b>
T 10,10,0,3,pt15;memory card	
A 1[NO PRINT]	
Ms LBL	End of save command

- After transfer of the command sequence, the file XYZ is saved with the commands from J to A.
- Only one label is printed each time the file XYZ is called up.
- The [NO PRINT] parameter in command A suppresses the printing of a label when the file is saved.
- To print the label a variable number of times, use command A [?].

## 14.5 Storage Device Functions

### 14.5.1 Load Label

Labels whose descriptions are saved on the storage device can be printed using the *Load label* function.

- ▶ Start menu.
- ▶ Select *Storage > Load label*.  
The display shows the selection of external storage devices and the label files stored on the devices.
- ▶ Select a label and confirm with .  
If a label is selected which was saved with a fixed contents and fixed label quantity, the print job is started immediately.  
If additional input on the label description is required, the display requests to enter the variable data.  
For label descriptions with a variable label quantity, a prompt to enter the label quantity is displayed.
- ▶ Enter the label quantity/variable data and select  to start the print job.

## 14 Storage Devices

### 14.5.2 Print File List

The *Print file list* function creates a list of the files stored on the default storage device.



- ▶ Insert printable medium (labels, continuous label media) which extends across the entire printing width.
- ▶ If the printout is to occur using thermal transfer printing, insert transfer ribbon with the maximum width.
- ▶ Start menu.
- ▶ Select *Storage > Print file list*  
The display shows the selection of storage devices
- ▶ Select a storage device and confirm with  .  
The directory of the storage device will be printed.

Contents of the printout:

- the name of the storage device
- information on the saved files
- the size of the available memory area

### 14.5.3 Copy Files

With the *Copy files* function files can be copied from one to another storage devices.

- ▶ Insert the storage devices.
- ▶ Start menu.
- ▶ Select *Storage > Copy files*.  
Under the headline *Source* the selection of storage devices will be shown.
- ▶ Select source device.
- ▶ Select a folder.
- ▶ Select files. One single file or all files (\*.\*) of the folder can be selected.
- ▶ Confirm the selection with  .  
Under the headline *Destination* the selection of storage devices will be shown again.
- ▶ Select destination device and folder.
- ▶ Confirm the selection with  .  
The files are copied. The display shows the message "*Copied ... file(s) to [Destination]*"
- ▶ Select *Continue* to return to the *Storage* menu.

### 14.5.4 Format Storage

The *Format* function can be used to delete all data from a storage device. This reformats the storage device. So you can also use the *Format* function if the *Unknown card* error message appears when using the device.

- ▶ Insert storage device
- ▶ Start menu.
- ▶ Select *Storage > Format storage*.  
If the function is protected via a PIN a prompt appears in the display. Enter the code number and confirm with *OK*.  
The display shows the selection of storage devices.
- ▶ Select a storage device and confirm the selection with  .  
The display shows the message *All data on the selected device will be lost*.
- ▶ Select *Continue*. The storage device will be formatted.  
Do not remove the device from the printer during the deleting procedure.  
The printer returns to the *Storage* menu.

## 14 Storage Devices

### 14.5.5 Default Storage

With the parameter *Default storage* Definition the storage device can be defined, which can be operated via interfaces and FTP printer management.

At functions started from the printer display all storage devices are accessible, but the default storage will be offered first.

- ▶ Start menu.
- ▶ Select *Storage > Default storage*.  
The display shows the selection of storage devices.
- ▶ Select a storage device and confirm the selection with  .

## 15 Remote Access via VNC



### Attention!

**For the remote access via VNC the firmware version 5.03 or later must be installed.**

VNC is a software that allows remote control of a printer's operation control panel (server) via a computer (client) through input devices like keyboard and mouse.

VNC is not platform dependent and enables the use of a Windows computer as well as a mobile Android or iOS system as an external remote control. The prerequisite for this is the installation of a VNC client on the system used.

#### Preparing the Computer

- ▶ Install the VNC client on the computer.

#### Preparing the Printer

- ▶ Activate the VNC server under *Setup > Interfaces > Network services > VNC server*.
- ▶ Enter password *vnc* under *Security > Password VNC*.

For Wireless Access:

- ▶ Activate Wi-Fi under *Setup > Interfaces > Wi-Fi > Wi-Fi*.
- ▶ Find out the Wi-Fi-IP-Address under *Info*.

For Ethernet Access:

- ▶ Find out the Ethernet-IP-Address under *Info*.

#### Establishing a Connection

- ▶ Start the VNC client on the computer.
- ▶ Enter the IP address and password *vnc* in the configuration of the VNC client.
- ▶ Activate the connection.  
The menu of the printer will be visible and usable via mouse click, keyboard or touch-pad just like on the printer itself.

## 16 External Keyboard

An external keyboard or a compatible input device (e.g. barcode scanner) can be connected directly to the printer. Using an external keyboard facilitates the entry of variable data while processing print jobs and printing from storage devices.

Input prompts and the data received from the keyboard are shown in the display.

### 16.1 Connecting External Keyboard

Any HID compatible USB keyboard can be connected to the printer.

- ▶ Insert connection cable of the keyboard into a USB master interface of the printer.

### 16.2 Keyboard Assignment

- ▶ If necessary set the parameter *Setup > Region > Keyboard* matching to the used keyboard.



**Notice!**

- ▶ If the parameter *Keyboard* is set to *Automatic*, the keyboard assignment will be defined by the setting of the parameter *Country*.

The following *Country* settings have special keyboard assignment :

Country	Keyboard
China	USA
South Africa	USA
Taiwan	USA
Mexico	Latin America
Egypt	Arabic

Table 33 Special assignments *Country - Keyboard*

For the following *Keyboard* settings can be switched between two assignments by pressing the CTRL key and the SHIFT key:

Keyboard	First assignment	Second assignment
Bulgaria	Latin	Cyrillic
Greece	Latin	Greek
Iran	Latin	Persian
Macedonia	Latin	Cyrillic
Russia	Latin	Cyrillic
Thailand	Latin	Thai
Arabic	Latin	Arabic

Table 34 *Keyboard* settings with double assignment

## 16 External Keyboard

### 16.3 Special Key Functions

General :





[F1]	Executes the <i>Load label</i> storage device function.
[F2]	Prints an additional label from the last print job. Corresponds to  .
[F3]	Repeats the last print job with renewed polling of the variable data and polling of the label quantity.
[F8]	Functions like  .
[Enter]	Starts menu
[Esc]	Functions like  .
[Space]	Functions like  .

Table 35 Special key functions: general

**In the menu and for entry of variable data:**

[Enter]	Confirms the input.
[Esc]	Cancels the input and returns.
[Shift][Entf]	Clears the input line.

Table 36 Special key functions: Menu and data input



#### **Attention!**

**When using a scanner operated as keyboard emulation ensure that the same character set is set for both the scanner and the printer.**

## 17 Updating Firmware on the i7100 Industrial Label Printer

Your printer's firmware can easily be upgraded. There are several methods for firmware updating that may be available depending on your printer's configuration and/or network situation.

**Contact your local Brady Technical Support location to update your printer's firmware.**

The following chart shows the locations and contact information for Brady's global Technical support locations.

<b>Americas</b>		
Canada	1-800-643-8766	bradycanada_technicalsupport@bradycorp.com
United States	1-800-643-8766	tech_support@bradycorp.com
Mexico	1-800-212-8181	soporte_tecnico@bradycorp.com
Central America & Caribbean	1-866-748-4424	soporte_tecnico@bradycorp.com
Brazil	+55 11 4166-1500 ext 5	at@bradycorp.com
Rest of South America	1-866-748-4424	soporte_tecnico@bradycorp.com

<b>Europe, Middle East, Africa</b>		
Main Support Center	+44 333 333 1111	tseurope@bradycorp.com
English and native language support for 22 countries depending on location	for local phone number list visit: <a href="http://www.bradycorp.com/technical-support/brady-solution-center">http://www.bradycorp.com/technical-support/brady-solution-center</a>	

<b>Asia Pacific</b>		
Australia / New Zealand	1-800-644-834	autech@bradycorp.com
China	4006-151-869	contactus_cn@bradycorp.com
Hong Kong / Taiwan	852-22169289/22169283	hksales@bradycorp.com
Korea	+82 2 861-8541 D14	TS_Korea@bradycorp.com
Japan	+81-42-655-2534	ap_japan_tech@bradycorp.com
Singapore / Malaysia / Indonesia	+65 64777237	technicalsupport_sa@bradycorp.com
Thailand / Vietnam	+65 64777237	technicalsupport_sa@bradycorp.com
Philippines	+65 64777237	technicalsupport_sa@bradycorp.com
India	+91-80-66582950	service_india@bradycorp.com

## 18 Index

<b>A</b>		<b>H</b>		<b>S</b>	
Apply/Print .....	17	Heat level .....	14	Save data stream .....	37
ASCII dump mode .....	34			Save print image .....	38
<b>B</b>		<b>I</b>		Save settings .....	40
Backfeed .....	14	IFFS .....	54, 56	Security tab .....	26
Backfeed position .....	16	Important information .....	5	Service key .....	11
Baud rate .....	19	Interfaces .....	18	Setup tab .....	25
Blowing air .....	17	Interpreter .....	22	Single print mode .....	15
Blow on .....	17	I/O interface		Stamp on .....	17
Blow time .....	17	Internal circuits .....	47	Starting position .....	17
Bluetooth .....	8, 22	Pin assignment .....	46	Status print .....	29
Brightness .....	22	Solution examples .....	48	Status tab .....	24
<b>C</b>		IP .....	18	Storage device functions .....	57
cabFirmwareUpdater .....	62	<b>J</b>		Storage devices	
Calibrate sensor .....	44	JScript .....	22	Directory structure .....	56
Character set .....	22	<b>K</b>		Installation .....	56
Cleaning interval .....	42	Keyboard .....	60	Print labels .....	57
Connecting to computer .....	6	Key functions .....	61	Writing .....	57
Control characters .....	34	<b>L</b>		Supporting air .....	17
Country .....	21	Labelling .....	17	Switch-off delay .....	17
Cut offset .....	16	Label profile .....	35	Switch-on delay .....	17
Cutting .....	16	Labels .....	15	<b>T</b>	
<b>D</b>		Label sensor .....	15	Tearing-off .....	16
Date .....	21	Legal notices .....	42	Tear-off mode .....	16
Daylight saving .....	21	Length correction .....	44	Tear-off position .....	16
Device list .....	31	Load label .....	57	Test grid .....	32
Devices tab .....	27	Load settings .....	41	Time .....	21
DHCP .....	18	<b>M</b>		Time powersave .....	22
<b>E</b>		Menu .....	9	Transfer print .....	15
Errors .....	20	<b>N</b>		<b>U</b>	
Ethernet .....	18	Network services .....	19	USB memory .....	56
Ethernet interface .....	6, 7	<b>P</b>		USB slave interface .....	6
Event log .....	36	Passwords .....	54	<b>V</b>	
Extrapolate labels .....	15	Peeling-off .....	16	Vacuum sensor .....	17
<b>F</b>		Print/Apply .....	17	<b>W</b>	
Firmware update		Printing .....	14	Waiting position .....	17
from storage device .....	40	Printing intensity .....	14	Web interface .....	23
via cabFirmwareUpdater .....	62	Printing offset .....	14	Windows printer setting .....	6
via FTP .....	55	Print services .....	6	WLAN .....	18
via web interface .....	28	Print speed .....	14	WLAN status .....	33
Firmware version .....	24	Protocol .....	19	<b>Z</b>	
Font list .....	30	<b>R</b>		ZPL .....	22
Font tab .....	27	Raw-IP .....	6		
Format storage .....	58	Region .....	21		
FTP .....	46, 54	Reset service counter .....	44		
FTP login .....	54	Reset settings .....	41		
FTP server .....	54	Ribbon .....	15		
<b>G</b>		Roll on .....	17		
Gateway .....	18	Roll-on time .....	17		
		RS-232 .....	19, 20, 22		

## Locations

### Brady Worldwide, Inc

6555 West Good Hope Road  
P.O. Box 2131  
Milwaukee, WI 53201-2131  
www.bradycorp.com  
Tel: 800- 537-8791

### Brady EMEA

Lindestraat 20  
9240 Zele  
Belgium  
www.bradycorp.com/global  
Tel: +32 (0) 52 45 78 11

### Brady Corporation Asia

1 Kaki Bukit Crescent  
Singapore 416236  
www.bradycorp.com/global  
Tel: 65-6477-7261

### Brady Worldwide

Australia.....	612-8717-6300
Brazil.....	55-11-3686-4720
Canada.....	1-800-263-6179
China (Beijing).....	86-10-6788-7799
China (Shanghai).....	86-21-6886-3666
China (Wuxi).....	86-510-528-2222
Hong Kong.....	852-2359-3149
Japan.....	81-45-461-3600
Korea.....	82-31-451-6600
Latin America.....	1-414-540-5560
Malaysia.....	60-4-646-2700
Mexico.....	525-399-6963
New Zealand.....	61-2-8717-2200
Philippines.....	63-2-658-2077
Singapore.....	65-6477-7261
Taiwan.....	886-3-327-7788
Thailand.....	66-2-793-9200